

TiAM

kwartalnik naukowo-techniczny

e-ISSN-2450-8217

TECHNOLOGIA I AUTOMATYZACJA MONTAŻU

ZESPOŁÓW • MASZYN • URZĄDZEŃ



2/2020

Wydawca: Łukasiewicz - IMBiGS • Wydawnictwo SIGMA-NOT • Patronat: SIMP • Istnieje od 1993 r. • Open Access on www.sigma-not.pl • Zeszyt nr 2-2020 (108)



fol. Pixabay

PRASA FACHOWA

SIGMA-NOT 
www.sigma-not.pl



Łukasiewicz
IMBiGS

e-ISSN-2450-8217

ZESPÓŁ REDAKCYJNY:**Redaktor Naczelny** – prof. dr hab. inż. Jerzy Łunarski
Z-ca Redaktora Naczelnego – dr inż. Martyna Jachimowicz
tel. 663 311 966**Redaktorzy tematyczni:**Dr inż. Rafał Kluz (technologia, automatyzacja)
Dr inż. Katarzyna Antosz (niezawodność, eksploatacja)
Dr inż. Mirosław Chłosta (inżynieria, produkcja)
Dr inż. Andrzej Kubit (struktury i systemy montażu)**RADA PROGRAMOWO-NAUKOWA:**

Prof. Dario Antonelli (Politecnico di Torino, Włochy), prof. Bronius Baksys (Kaunas University of Technology, Litwa), prof. Marek Balaziński (Ecole Polytechnique Montreal, Kanada), prof. Adam BARYLSKI (Politechnika Gdańska), mgr inż. Magdalena Borek-Daruk (SIGMA-NOT), prof. Józef Gawlik (Politechnika Krakowska) – z-ca przewodniczącego, prof. Jan Godzimirski (WAT), prof. Stefan Góralczyk (IMBiGS), prof. Mikulas Hajduk (Technika Univerzita v Koscicach, Słowacja), prof. Michael Kneifetz (Polski Gosudarstwiennyj Uniwersytet, Biaoruś), doc. dr inż. Radek Knoflicek (FME Brno, Czechy), prof. Mark Kristal (Volgograd State Technical University, Rosja), prof. Józef Kuczmaszewski (Politechnika Lubelska), prof. Piotr Łebkowski (AGH), prof. Antonio Maffei (KTH Royal Institute of Technology, Szwecja), prof. Ignace Martens (Katholieke Universiteit Leuven, Belgia), prof. Jacek Mucha (Politechnika Rzeszowska), prof. Vitaliy Pasichnyk (Nacjonalnyj Techniczeskij Uniwersitet Ukrainy „Kijewskij Politechniczeskij Instytut”, Ukraina), prof. R. M. Chandima Ratnayake (University of Stavanger, Norwegia), prof. Emil Spisak (Technika Univerzita v Koscicach, Słowacja), dr inż. Dorota Stadnicka (Politechnika Rzeszowska), prof. Jerzy Stamirowski (Politechnika Świętokrzyska), prof. Michaił W. Watanow (Moskowskij Gosudarstwiennyj Maszinstroitelnyj Uniwersytet, Rosja), prof. Władimir P. Woronienko (Moskowskij Gosudarstwiennyj Technologiczeskij Uniwersytet, Rosja), prof. Jan Żurek (Politechnika Poznańska) – przewodniczący

ADRES REDAKCJI:Kwartalnik „Technologia i Automatykacja Montażu”
ul. Ratuszowa 11, pok. 740, 03-450 Warszawa
Tel. 22 853 81 13
e-mail: tiam@sigma-not.pl
www.tiam.pl**PRENUMERATA:**Zakład Kolportażu Wydawnictwa SIGMA-NOT Sp. z o.o.
ul. Ku Wiśle 7, 00-707 Warszawa
tel. 22 840 30 86
tel./fax: 22 827 43 65, 619 22 41 w. 215
e-mail: prenumerata@sigma-not.pl
portal: www.sigma-not.pl**REKLAMA:**Redakcja: tel. 22 853 81 13
e-mail: tiam@sigma-not.pl
Dział Reklamy i Marketingu
tel./fax: 22 827 43 65
e-mail: reklama@sigma-not.pl**SKŁAD I ŁAMANIE:**Wydawnictwo SIGMA-NOT
ul. Ratuszowa 11, 03-450 Warszawa
e-mail: sekretariat@sigma-not.pl**WYDAWCZA:****Łukasiewicz**
IMBiGSSieć Badawcza Łukasiewicz
Instytut Mechanizacji Budownictwa i Górnictwa Skalnego
ul. Racjonalizacji 6/8, 02-673 WarszawaWydawnictwo SIGMA-NOT
ul. Ratuszowa 11, 03-450 Warszawa**PATRONAT:**Stowarzyszenie Inżynierów Mechaników i Techników Polskich
Za treść ogłoszeń i artykułów promocyjnych redakcja nie odpowiada
Wersja pierwotna: elektroniczna**WSKAZÓWKI DOTYCZĄCE PRZYGOTOWANIA ARTYKUŁÓW**

- Artykuły przeznaczone do opublikowania w kwartalniku „Technologia i Automatykacja Montażu” powinny mieć oryginalny i naukowo-techniczny charakter i być zgodne z problematyką czasopisma. Redakcja przyjmuje artykuły w jęz. polskim, jęz. angielskim i jęz. rosyjskim.
- Artykuł o maksymalnej objętości 5 stron A4 wraz z ilustracjami powinien być napisany czcionką Times Roman lub Arial 12 pkt, z interlinią 12 pkt. Formatowany tekst nie powinien mieć podziału na kolumny.
- Tytuł artykułu należy podać w jęz. polskim i jęz. angielskim. Tytuł nieprzekraczający 10 słów powinien odzwierciedlać istotne elementy treści artykułu.
- Struktura artykułów naukowo-technicznych prezentujących prace autora(ów) powinna być następująca: wstęp (wprowadzenie); metodyka (badań, analiz, pracy z podaniem ewentualnie materiałów, założeń itp.); wyniki (badań, analiz); omówienie wyników; wnioski; spis literatury.
- Podpisy pod ilustracjami oraz tytuły tablic należy podać w jęz. artykułu i jęz. angielskim.
- Ilustracje należy dołączyć również jako osobne pliki w formacie: .jpg, .tiff, z rozdzielczością co najmniej 300 dpi. Wszystkie zamieszczone ilustracje powinny być własnością autora(ów) lub należy podać źródło pochodzenia rysunków.
- Wzory matematyczne pisane w edytorze równań Microsoft Equation i powinny być oznaczane kolejnym numerem w nawiasie okrągłym. Wszystkie symbole powinny być objaśnione. Należy stosować jednostki układu SI.
- Spis literatury należy podać w kolejności cytowania w tekście, a odnośniki w tekście winny być ponumerowane cyframi arabskimi i umieszczone w nawiasach kwadratowych. W przypadku korzystania z Internetu należy podać adres strony i datę odczytu. Liczbę autocytoowań należy ograniczyć do niezbędnych.
- Do artykułu należy dołączyć streszczenie w jęz. artykułu i jęz. angielskim, zawierające minimum 200–250 słów.
- Pod streszczeniem należy podać 3–6 słów kluczowych w jęz. artykułu i jęz. angielskim, zwracając uwagę, by nie były one powtórzeniem tytułu pracy.
- Po spisie literatury zaleca się podanie źródła finansowania pracy.
- Na końcu artykułu należy podać: imiona i nazwiska autorów, tytuły naukowe lub zawodowe, telefon, faks, e-mail, miejsce zatrudnienia wraz z adresem do korespondencji.

PROCEDURA RECENZOWANIA

Procedura recenzowania artykułów w czasopiśmie jest zgodna z zaleceniami Ministerstwa Nauki i Szkolnictwa Wyższego zawartymi w opracowaniu „Dobre praktyki w procedurach recenzyjnych w nauce”, Warszawa 2011.

Wszystkie artykuły naukowo-techniczne publikowane w kwartalniku „Technologia i Automatykacja Montażu” są recenzowane.

Nadesłane artykuły są poddawane redakcyjnej ocenie formalnej i otrzymują numer redakcyjny, identyfikujący je na dalszych etapach procesu wydawniczego, a redakcja wysyła do autorów informację o przyjęciu artykułu i wysłaniu go do recenzentów. Do oceny każdej publikacji powołuje się co najmniej dwóch niezależnych recenzentów. Redakcja dobiera recenzentów rzetelnych i kompetentnych w danej dziedzinie. Nadesłane artykuły nie są nigdy wysyłane do recenzentów z tej samej placówki, z której pochodzi autor. Prace recenzentów są poufne i anonimowe. Recenzja musi mieć formę pisemną i kończyć się jednoznacznym wnioskiem o dopuszczeniu artykułu do publikacji w czasopiśmie lub jego odrzuceniu. W przypadku pracy w języku obcym, co najmniej jeden z recenzentów jest afiliowany w instytucji zagranicznej innej niż narodowość autora pracy. Autorzy są informowani o wynikach recenzji oraz otrzymują je do wglądu. W sytuacjach spornych redakcja powołuje dodatkowych recenzentów.

Lista recenzentów publikowana jest w ostatnim zeszycie każdego rocznika.

Kwartalnik „Technologia i Automatykacja Montażu” ukazuje się formie elektronicznej w otwartym dostępie (Open Access) i jest dostępny na Portalu Informacji Technicznej Wydawnictwa SIGMA-NOT
www.sigma-not.pl

4

MAGIERA M.:

Hierarchical method of rescheduling for assembly lines with intermediate buffers

Hierarchiczna metoda reharmonogramowania montażu w liniach montażowych z buforami międzyoperacyjnymi

9

CIEŚLAK R., KAŁUŻNA J., PETA K., SUSZYŃSKI M., WIŚNIEWSKI M.:

Evaluation and choice of a wrapper for packing products using the AHP method

Ocena i wybór rozwiązania do pakowania urządzeń elektrycznych z zastosowaniem metody AHP

16

GODZIMIRSKI J., ROŚKOWICZ M.:

Selection of joints for testing a fatigue life of aviation rivets

Dobór połączeń do badania trwałości zmęczeniowej nitów lotniczych

21

BASARA D., SKOCZYLAS L.:

Importance and control of geometric and kinematic accuracy in precision machining of parts in assembly operation aspect

Znaczenie geometrycznej i kinematycznej kontroli dokładności maszyn w dokładnej obróbce części w aspekcie operacji montażu

27

BAK Ł., GUŻLA E., ŁYKO M.:

Analysis of the impact of surface roughness on the capacity of adhesive joints from aluminum alloy 2024

Analiza wpływu chropowatości powierzchni na nośność połączeń klejowych stopu aluminium 2024

34

DOMIŃCZUK J., KRAWCZUK A.:

Comparative analysis of wetting ability of aluminum sheets with different surface roughness parameters by epoxy adhesive

Analiza porównawcza zdolności zwilżania przez klej epoksydowy blach aluminiowych o różnych parametrach chropowatości powierzchni

41

BARYLSKI A.:

Analysis of flat compensator lapping in an assembly process

Analiza docierania kompensatora płaskiego w procesie montażu

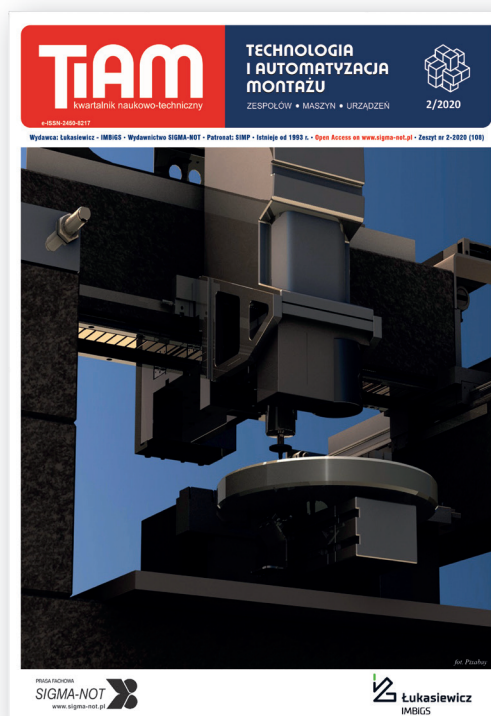

Sfinansowano ze środków Ministerstwa Nauki i Szkolnictwa Wyższego na podstawie umowy nr 460/WCN/2019/1 z dnia 24.07.2019 r. stanowiących pomoc przyznana w ramach programu „Wsparcie dla czasopism naukowych”



TECHNOLOGIA I AUTOMATYZACJA MONTAŻU

e-kwartalnik naukowo-techniczny

w otwartym dostępie na:
www.tiam.com.pl
www.sigma-not.pl

**Autorów zapraszamy do publikacji
na łamach kwartalnika – 20 pkt. MNiSW**
kontakt: tiam@sigma-not.pl
tel. 22 853 81 13



WYDAWNICTWO SIGMA-NOT 

MULTITUDE OF PROBLEMS AND DIFFICULTIES

Jerzy ŁUNARSKI

The unexpected attack of a viral epidemic resulted in a crisis situation much more serious than any former economic, social, political or other postwar crises.

Coming through this situation is particularly difficult for small and medium enterprises (SME) as well as for various organisations, institutions and individual entities. In the present situation various problems, both known and new, which need to be dealt with appear. In the past practice of the civilizational development lots of effective procedures and methods that facilitate solving problems or at least reduce their negative impact were worked out. In order to remind these methods, a general algorithm of a recommended procedure, in which some steps may be omitted depending on particular conditions, understanding of the problem and available resources for its solution were presented here. These are as follows:

1. **Problem identification** that is based on defining its name, revealing its quality and quantity features, assigning it to a particular knowledge domain.
2. **Problem situation identification** that is based on defining the significance of a problem for an organization (priority of procedure), pre-problem situation, limitations caused by the problem and the possibilities of its solving as well as the criteria according to which the revitalization activities should be assessed, and the indications of the detailed tasks that should be undertaken.
3. **Problem analysis** during which the methods and techniques that will help to solve this problem should be chosen; a rational plan of action should be developed and the concepts of possible variants should be formulated in order to solve the problem.
4. **Variant choice**, possibly the most beneficial for an organization, based on a preliminary comparison of:
 - The possibilities of its realization in a specific situation, the present limitations and the adopted criteria of assessment,
 - The economic effectiveness including available resources, possible to allocate for solving the problem,
 - The availability of the required personnel, infrastructure and possible external support.

Such comparison should result in the choice of a variant most beneficial for an organisation.

5. **Detailed project** of a chosen variant of action, including the performance of necessary engineering analyses, calculations and other procedures amending the solution to the needs of an organization and the limitations, the development of detailed plans and schedules of realization as well as the indication of the resources possible to use. The project should be assessed according to the adopted criteria, and if possible, it should be improved (e.g. with verification, FMEA analysis, risks assessment, etc.) before starting its realization.
6. **Implementation of the developed project** enabling the problem solution, the results control and their assessment according to the established criteria, and in case of unsatisfactory results, the introduction of the proper modifications of the project in order to obtain the desired results.

Each step of the above mentioned procedure requires the engagement of knowledge, resource-fulness and innovation of the people or teams appointed to solve the problem. The situation becomes complicated when a lot of different problems are interdependent, and thus they should be considered comprehensively. In the practice of organization's operation a number of different approaches are used. The examples of some, characterized by well-known acronyms, are among others:

- PDCA – Plan-Do-Check-Act,
- DMAIC – Define, Measure, Analyze, Improve and Control of the obtained results,
- SMART (goal designation) – Specific, Measurable, Achievable, Relevant, Time-bound,
- CIMDO – Consistent Information Multivariate Density Optimizing, and other.

In conclusion, it should be underlined that „good advice" is useless without too much engagement, knowledge, initiative and hard-work of the committed personnel who need to solve these problems.

TiAM editors wish its readers good luck in solving the accumulated problems.

HIERARCHICAL METHOD OF RESCHEDULING FOR ASSEMBLY LINES WITH INTERMEDIATE BUFFERS

Hierarchiczna metoda reharmonogramowania montażu w liniach montażowych z buforami międzyoperacyjnymi

Marek MAGIERA

ORCID 0000-0002-9026-4020

DOI: 10.15199/160.2020.2.1

Abstract: A method of scheduling assembly in flexible assembly lines without parallel machines is presented. The method applies to lines fitted with intermediate buffers with limited capacities. The developed method is distinguished by the possibility of rescheduling. This is very significant in the case of a need to provide for new, urgent orders, as well as machine failures. The first level of the method concerns balancing the load of the assembly machines. Starting times of individual operations are determined at the second level of the method. Integer programming was used to solve the tasks allocated to both levels of the method. The results of computational experiments regarding the method are described.

Keywords: scheduling, optimization, assembly routes, integer programming, heuristic

Streszczenie: Zaprezentowano metodę budowy harmonogramów montażu w elastycznych liniach montażowych bez maszyn równoległych. Metoda dotyczy linii wyposażonych w bufor międzyoperacyjne o ograniczonych pojemnościach. Opracowaną metodę wyróżnia możliwość reharmonogramowania. Ma to duże znaczenie w przypadku konieczności uwzględnienia nowych, pilnych zleceń, a także awarii maszyn. Pierwszy poziom metody dotyczy równoważenia obciążeń maszyn montażowych. Wyznaczenie czasów rozpoczęcia wykonywania poszczególnych operacji dokonywane jest na poziomie drugim metody. Do rozwiązania zadań przyporządkowanych obu poziomom metody zastosowano programowanie całkowitoliczbowe. Zamieszczono wyniki eksperymentów obliczeniowych dotyczących metody.

Słowa kluczowe: harmonogramowanie, optymalizacja, marszruty montażu, programowanie całkowitoliczbowe, heurystyka

Introduction – the reasons for construction of the method

Variable conditions of the assembly process often disturb performance of the designated assembly schedule. Malfunctions of the assembly machines and the resulting limited availability of the machines often cause inability to assemble the products in accordance with the original schedule. In such a case, it is recommended to rebuild the assembly schedule, taking into account the limited availability of the assembly machines. This action is referred to as rescheduling.

Another reason for rescheduling is to take into account new, urgent orders for product assembly. This gives a competitive advantage, as new orders can be completed in a relatively short time. Rescheduling can also be the result of modified requirements of the customers [7]. The reasons for rescheduling and the associated issues are described in detail in papers [3] and [14].

The aforesaid technical (limited machine availability) and economic (ability to complete the new orders in a short time) aspects are the cause of creating the assembly rescheduling method, described further on.

It should be emphasized that each rescheduling is a specific type of scheduling. Assembly scheduling

consists in assignment of assembly operations to the machines and determining the starting times for these actions [8]. In the case of the developed method, it is possible to retain a part of the original schedule, and rescheduling is only performed for certain products.

The rescheduling method concerns simultaneous assembly of numerous products of different types. This involves the need to take into account numerous parameters and variables, which affects the computational complexity and duration of the computations related to the creation of a new schedule. The issues related to processing of large amounts of data are broadly discussed in study [12]. In order to reduce the size of the problems to be solved, the hierarchical concept was applied. The developed method is two-level. At the first level, operations are assigned to the machines; the second level is about separating the operations in time. An alternative concept is the monolithic approach, where both tasks are solved simultaneously. The advantages and disadvantages of both concepts are described in the study [12].

The literature covering the issues of task scheduling for production flow systems is very rich. The papers [10] and [15] are dedicated to the description of the review of

the used methods. The authors of the paper [10] have classified these methods. They have presented monolithic and hierarchical methods used for determination of optimum solutions, heuristics, and hybrid approaches. The classification of the methods used for task scheduling for multi-stage assembly lines is described in the paper [9]. Creation of presented in the paper mathematical models concerning the developed method was inspired, e.g., by the studies: [8], [11], and [13]. These papers show very good perspectives for using mathematical programming in assembly planning.

General description of the hierarchical method

The method applies to unidirectional assembly lines with intermediate buffers of limited capacities. In these buffers, the products await performance of subsequent operations only when it is not possible to transport the product to the next machine, or the next machine performs operations on another product. An example of an assembly line setup is shown in Fig. 1. It is an assembly system without parallel machines.

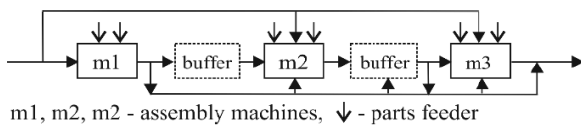

Fig. 1. Unidirectional assembly line with intermediate buffers

A block diagram of the developed method is shown in Fig. 2. At the first level, the assembly operations are assigned to the machines. Some of the operations can be performed in accordance with the original schedule, if the decision-maker so chooses. The machine loads are equivalent. At the second level, operation starting times are determined for the rescheduled products. The shortest possible schedules are determined.

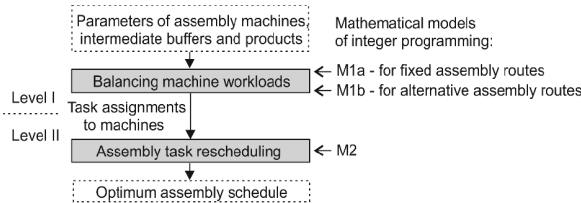

Fig. 2. Block diagram of the two-level method

The rescheduling method includes two types of assembly routes. In the case of fixed routes, every type of operation is assigned to exactly one machine. Alternative assembly routes are characterized by the fact that each type of operation is assigned to at least one machine.

In order to solve the problems regarding individual levels, integer programming was applied. Designations of the constructed linear mathematical models assigned to individual levels are listed in Fig. 2.

Use of the integer programming made it possible to computation solutions to optimum partial tasks concerning the individual levels of the method. Yet, as the hierarchical concept was applied, the designated schedule may be encumbered with a deviation from the optimum. The developed method is classified as heuristic. The issues concerning heuristics are described, e.g., in studies [4] and [5]. One of the advantages of the heuristics applied is the possibility of solving large tasks in a relatively short time.

The following chapters present the mathematical description of the developed method, followed by the results of the computational experiments concerning the method.

Mathematical description of the hierarchical method

A list of designations used in the created mathematical models regarding individual levels of the method can be found in Tab. 1. Among the parameters and sets listed in this table, one can distinguish data concerning the original schedule (e.g. set Z), as well as data describing the products which require rescheduling.

Table 1. Notation of sets, parameters and variables used in the mathematical models

Basic sets:	
I	– the set of assembly machines; $I = \{1, \dots, M\}$;
J	– the set of types of assembly operations; $J = \{1, \dots, N\}$;
K	– the set of types of assembly products; $K = \{1, \dots, W\}$;
L	– the set of periods; $L = \{1, \dots, H\}$;
Others sets:	
I_j	– the set of the assembly machines capable of performing operation j ;
J_k	– the set of assembly operations required for product k , $J_k \subset J$;
J^c	– the set of operations which require using the part feeder, $J^c \subset J$;
K^1	– the set of products which are to be assembly in accordance with the original schedule, $K^1 \subset K$,
K^2	– the set of products which are to be assembly in accordance with the new schedule, $K^2 \subset K$;
R	– the set of three elements (k, r, j) , in which operation $j \in J_k$ is performed immediately before operation $r \in J_k$, and $k \in K^2$;
Z	– the set of three elements (i, k, l) , in which product $k \in K^2$ is assembly in accordance with the original schedule using the machine $i \in I$ during the period $l \in L$;
Parameters:	
a_{ij}	– working space required for assembly operation j at machine i ;
b_i	– total working space of the assembly machine i ;
d_i	– capacity of buffer located before assembly machine i ;
g_n	– transport time between assembly machines r and i ;
η_{il}	= 1, if machine i is available during period l , otherwise $\eta_{il} = 0$;
p_{ik}^1	– assembly time for assembly of product $k \in K^1$ loading machine i ;
p_{jk}^2	– assembly time for operation j of product $k \in K^2$;
r_{il}	– reserved space of the buffer located before the machine i , where, during period, l , the product assembled as per the original schedule will be stored;
Variables declared for the M1a and M1b models:	
x_{ij}	= 1, if type of assembly operation j is assigned to machine i , otherwise $x_{ij} = 0$;
z_{jk}	= 1, if product k is assigned to machine i to perform assembly operation j , otherwise $z_{jk} = 0$;
P_{max}	maximum machine workload;
Variables declared for the M2 model:	
q_{ikt}	= 1, if product k is assigned to machine i in period l , otherwise $q_{ikt} = 0$;
y_{ikt}	– capacity of the buffer located before machine i occupied by product k in period l ;

Level I of the developed method concerns assignment of operations to the assembly machines. This is done by solving the task of balancing the machine load, formulated in the form of integer programming task models. These models are presented below.

$$\text{Minimize: } P_{\max}; \quad (1)$$

$$\text{Subject to: } \sum_{k \in K^2} \sum_{j \in J_k} p_{jk}^2 z_{ijk} + \sum_{l \in L} (1 - n_{il}) + \sum_{k \in K^1} p_{ik}^1 \leq P_{\max}; \quad i \in I \quad (2)$$

$$\sum_{j \in J} x_{ij} = 1; \quad i \in I \quad \text{- only for the M1 model;} \quad (3)$$

$$\sum_{j \in J} x_{ij} \geq 1; \quad i \in I \quad \text{- only for the M2 model;} \quad (4)$$

$$\sum_{j \in J^c} a_{ij} x_{ij} \leq b_i; \quad i \in I; \quad (5)$$

$$x_{ij} = 0; \quad i \notin I_j; \quad j \in J; \quad (6)$$

$$z_{ijk} \leq x_{ij}; \quad i \in I; \quad j \in J_k; \quad k \in K^2; \quad (7)$$

$$\sum_{i \in I} z_{ijk} = 1; \quad j \in J_k; \quad k \in K^2; \quad (8)$$

$$\sum_{i \in I} z_{irk} \leq \sum_{i \in I} z_{ijk}; \quad (k, r, j) \in R; \quad (9)$$

$$x_{ij}, z_{ijk} \in \{0, 1\}; \quad i \in I; \quad j \in J; \quad k \in K^2 \quad (10)$$

The function of the objective (1) concerning models M1a and M1b represents the workload of the machine which forms a bottleneck in the assembly system. It is designated in constraint (2), which takes into account both the assignment of product operations to the machines and limited availability of the machines. This constraint takes into account the products which require rescheduling, as well as those assemblies in accordance with the original schedule. Constraint (3) applies only to model M1a and guarantees fixed assembly routes. In turn, constraint (4) applies to model M1b and enables alternative assembly routes in the created schedule. The following constraints guarantee: (5) – verification of working spaces for individual machines, in order to arrange the part feeders for individual products; (6) – elimination of assigning the operations to the wrong machines; (7) – assignment of operations regarding individual products to those machines which have the ability to perform the specific types of operations; (8) – assignment of all the operations involving rescheduled

The mathematical models M1 (for fixed routes) and M2 (for alternative routes)

products to the machines; (9) – taking into account the limitations concerning the sequence of the operation and the one-way flow of the products along the assembly line; (10) – binarity of the decision variables.

The determined variable values are the input data for the task solved at the 2nd level of the method. These include the durations of the machines being loaded by the rescheduled products. They are computed using equation (11). Machine workloads by products assembled in accordance with the original schedule are given, provided for in set Z (table 1).

$$t_{ik} = \sum_{j \in J_k} p_{jk}^2 z_{ijk}; \quad i \in I; \quad k \in K^2 \quad (11)$$

The 2nd level of the method includes scheduling of the operations concerning products which require a new schedule. Below is the mathematical model, concerning the 2nd level of the method.

The mathematical model M2

$$\text{Minimize: } \sum_{i \in I} \sum_{k \in K} \sum_{l \in L} q_{ikl}; \quad (12)$$

$$\text{Subject to: } \sum_{l \in L} q_{ikl} = t_{ik}; \quad i \in I; \quad k \in K^2; \quad (13)$$

$$q_{ikl} = 1; \quad (i, k, l) \in Z; \quad (14)$$

$$\sum_{k \in K} q_{ikl} = n_{il}; \quad i \in I; \quad l \in L; \quad (15)$$

$$l q_{ikl} - f q_{ikf} \leq t_{ik} - 1 + (H + 1)(1 - q_{ikf}); \quad i \in I; \quad l, f \in L; \quad l > f; \quad k \in K^2; \quad (16)$$

$$\frac{\sum_{l \in L} l q_{ikl}}{t_{ik}} - \frac{\sum_{l \in L} l q_{\tau kl}}{t_{\tau k}} - \frac{t_{ik} + t_{\tau k}}{2} \geq g_{\tau i}; \quad k \in K^2; \quad \tau, i \in I; \quad \tau < i; \quad t_{ik}, t_{\tau k} > 0; \quad (17)$$

$$\frac{\sum_{l \in L} l q_{ikl}}{t_{ik}} - \frac{\sum_{l \in L} l q_{\tau kl}}{t_{\tau k}} - \frac{t_{ik} + t_{\tau k}}{2} - g_{\tau i} = \sum_{l \in L} y_{ikl};$$

$$k \in K^2; \quad \tau, i \in I; \quad \tau < i; \quad t_{ik}, t_{\tau k} > 0; \quad \sum_{s=\tau}^i t_{sk} = t_{\tau k} + t_{ik}; \quad (18)$$

$$l y_{ikl} \geq \frac{\sum_{f \in L} f q_{\tau kf}}{t_{\tau k}} + \frac{t_{\tau k} + 1}{2} + g_{\tau i} - (H + 1)(1 - y_{ikl});$$

$$k \in K^2; \quad \tau, i \in I; \quad i > 1; \quad t_{\tau k} > 0; \quad l \in L; \quad \sum_{s=\tau}^i t_{sk} = t_{\tau k} + t_{ik}; \quad (19)$$

$$\frac{\sum_{f \in L} f q_{ikf}}{t_{ik}} - \frac{t_{ik} - 1}{2} - l y_{ikl} \geq 1; \quad k \in K^2; \quad l \in L; \quad i \in I; \quad i > 1; \quad t_{ik} > 0; \quad (20)$$

$$\sum_{k \in K} y_{ikl} + r_{il} \leq d_i; \quad i \in I; \quad i > 1; \quad l \in L; \quad (21)$$

$$q_{ikl}, y_{ikl} \in \{0, 1\}; \quad i \in I; \quad k \in K; \quad l \in L; \quad (22)$$

The minimized sum (12) guarantees construction of the shortest possible assembly schedules. The constraints regarding linear mathematical model M2 ensure: (13) – allocation of all the operations which cannot be performed as per the original schedule between the assembly machines; (14) – assembly as per original schedule for the assembly products to which the rescheduling does not apply; (15) – loading an assembly machine during its availability in a given period with a maximum of one assembly operation; (16) – indivisibility of operation performance in time and space – the operation is assigned to only one machine; (17) – order of operation performance in an unidirectional assembly line in accordance with a given assembly sequence and provision of time required for transport between machines; (18) – determination of time that given assembly products spend in the buffers; (19) and (20) – location of assembly products in appropriate buffers at a given period, before performing subsequent assembly operations; (21) – maintenance of the limited buffer capacities; (22) – binarity of all decision variables.

Computational experiments with the proposed hierarchical method

The presented method was verified using computational experiments. The mathematical models were coded in the AMPL language (*A Mathematical Programming Language*) [2], and *.mps files were generated. Computations were performed using the GUROBI optimizer [16]. The computational experiments enabled comparison of schedules including fixed and flexible assembly routes. Equation (23) defines the index f , intended to compare the length of the schedules. The schedule lengths were determined based on equation (24).

$$f = \frac{C_{\max}^{M1a,M2} - C_{\max}^{M1b,M2}}{C_{\max}^{M1b,M2}} \cdot 100\%; \quad (23)$$

C_{\max}^M – the length of schedule determined by means of the the M model.

$$C_{\max}^M = \max_{i \in I, k \in K, l \in L} l q_{ikl} \quad (24)$$

The computational experiments concerned four groups of test tasks. For each of these groups, 25 test examples were solved. The parameters of these task groups and the average values of the defined f index are shown in Tab. 2.

Table 2. Parameters of 4 groups of test tasks and average values of indexes f [%]

Group	Parameters of test tasks					Index f
	M	W	W'	N	H	
1	3	4	1	10	16	9.2
2	4	5	2	12	18	8.9
3	4	6	2	14	20	10.3
4	5	7	3	16	22	12.7

Numbers of: M – assembly machines, W – types of products, W' – types of products assembled according to the original schedule, $k \in K'$; N – types of assembly operations, H – periods.

The makespan has been divided into periods l (unitary time intervals) where $l \in L = \{1, \dots, H\}$. Taking into consideration too high a number of the periods may result in a major increase in the size of the solved problem, which may result in a relatively long computation time or lack of the possibility of finding any solution to the problem due to limited possibilities of the discrete optimization packets. A low value of the periods may result in the inability to solve the problem when assembly machines should be loaded for a longer time. The parameters H were determined based on the procedure described in the paper [6].

Thanks to the computational experiments, it was possible to measure the lengths of the schedules and compare them. The results presented in the table show that the fixed route schedules are about 9.2–12.7% longer than those which enable alternative routes. This results mostly from the fact that in the case of alternative routes, the load durations of individual machines are slightly different, unlike the schedules concerning alternative routes.

The computations times for fixed routes were about 18% shorter than those needed to determine schedules with alternative routes.

Conclusions

The most important advantage of this method is the possibility of rescheduling. This method enables creation of schedules where new operations can be added to pre-made schedules. This way, new, urgent orders can be completed in a relatively short time. This is a response to the market requirements which grants a competitive edge to any company that uses rescheduling. Another advantage of rescheduling is the possibility of quickly building new schedules in the case of machine malfunctions. The new schedule is adapted to the updated setup of the assembly line from which the damaged machine was eliminated.

The short times of building the new schedules result from application of the hierarchical concept. As the problem to be solved is divided into two tasks, the problems are smaller and the tasks can be solved in a shorter time. Another benefit of the presented multi-level method is an ability to solve problems of relatively larger sizes, compared to the monolithic method.

The presented two-level method, like any other hierarchical method [1], is characterized by a certain deviation from the optimum. However, for each partial task, an optimum solution is determined. This was achieved by applying integer programming in the constructed mathematical models. Of course, these models can be modified and adapted to the variable conditions of assembly and the requirements of the production market.

Wydanie publikacji finansowane przez Akademię Górniczo-Hutniczą im. Stanisława Staszica w Krakowie (dotacja podmiotowa na utrzymanie potencjału badawczego).

References

- [1] Ebadian M., Rabbani M., Torabi S.A. & Jolai F. 2009. „Hierarchical production planning and scheduling in make-to-order environments: reaching short and reliable delivery dates”. *International Journal of Production Research* 47(20): 5761–5789.
- [2] Fourer R., Gay D., and Kernighan B. 2003. *AMPL: A Modelling Language for Mathematical Programming*. Pacific Grove, CA: Duxbury Press.
- [3] Katragjini K., Vallada E., Ruiz R. 2013. „Flow shop rescheduling under different types of disruption”. *International Journal of Production Research* 51(3): 780–797.
- [4] Magiera M. 2016. *Wybrane metody planowania przepływów produktów przez linie produkcyjne i łańcuchy dostaw (Selected methods of planning product flows through production lines and supply chains)*. Kraków: Wydawnictwa AGH.
- [5] Magiera M. 2019. „Heuristic method of assembly scheduling of multi-option products for assembly line with intermediate buffers”. *Technologia i Automatyżacja Montażu* (3): 4–10.
- [6] Magiera M. 2013. „A relaxation heuristic for scheduling flowshops with intermediate buffers”. *Bulletin of the Polish Academy of Sciences. Technical Sciences* 61 (4): 929–942.
- [7] Modrak V., Soltysova Z., Stadnicka D. 2018. „Success factors and future trends in mass customization”. *Technologia i Automatyżacja Montażu* (2): 42–48.
- [8] Pindeo M.L. 2009. *Planning and Scheduling in Manufacturing and Services*. New York: Springer-Verlag.
- [9] Quadt D., Kuhn H. 2007. „A taxonomy of flexible flow line scheduling procedures”. *European Journal of Operational Research* 178 (3): 686–698.
- [10] Ribas I., Leinsteiner R., Framinan J.M. 2010. „Review and classification of hybrid flowshop scheduling problems from a production system and a solution procedure perspective”. *Computers & Operations Research* 37 (8): 1439–1454.
- [11] Ronconi D.P., Birgin E.G. 2012. „Mixed-Integer Programming Models for Flowshop Scheduling Problems Minimizing the Total Earliness and Tardiness”. In Ríos-Mercado R., Ríos-Solis Y. (eds) *Just-in-Time Systems*. Springer Optimization and Its Applications, 60. New York, NY: Springer.
- [12] Soualhia M., Khomh F., Tahar S. 2017. „Task Scheduling in Big Data Platforms: A Systematic Literature Review”. *The Journal of Systems and Software* 134: 170–189.
- [13] Tóth A., Knuutila T., Nevalainen O.S. 2018. „Machine configuration and workload balancing of modular placement machines in multi-product PCB assembly”. *International Journal of Computer Integrated Manufacturing* (9): 815–830.
- [14] Vieira G.E., Herrmann J.W. & Lin E. 2003. „Rescheduling manufacturing systems: a framework of strategies, policies, and methods”. *Journal of Scheduling* 6: 39–62.
- [15] Yadov A., Jayswal S.C. 2017. „Modelling of flexible manufacturing system: a review”. *International Journal of Production Research* 56(7): 2464–2487.
- [16] www.gurobi.com (Gurobi Optimizer, 2019).

dr inż. Marek Magiera
AGH Akademia Górniczo-Hutnicza w Krakowie, Katedra Badań Operacyjnych
al. A. Mickiewicza 30, 30-059 Kraków, Polska
e-mail: mmagiera@zarz.agh.edu.pl

EVALUATION AND CHOICE OF A WRAPPER FOR PACKING PRODUCTS USING THE AHP METHOD

Ocena i wybór rozwiązania do pakowania urządzeń elektrycznych z zastosowaniem metody AHP

Robert CIEŚLAK ORCID 0000-0002-1320-0410

Julia KAŁUŻNA

Katarzyna PETA ORCID 0000-0002-9915-838X

Marcin SUSZYŃSKI ORCID 0000-0001-7926-0574

Marcin WIŚNIEWSKI ORCID 0000-0001-7187-159X

DOI: 10.15199/160.2020.2.2

Abstract: The article presents the assessment and selection of wrapper for packaging the products in an electrical industry company according to the method of analytical, hierarchical decision making process (AHP). The decision making process was based on the available technical and operational parameters of wrappers from the leading manufacturers based on the selection criteria and their weights. The last part of the thesis contains a hierarchical structure of assessment and conclusions.

Keywords: AHP – Analytical Hierarchy Process, wrapper, assessment

Streszczenie: W artykule przedstawiono ocenę i wybór owijarki do pakowania produktów w firmie branży elektrycznej według metody analitycznego, hierarchicznego procesu decyzyjnego (ang. Analytical Hierarchy Process – AHP). Proces decyzyjny przeprowadzono w oparciu o dostępne parametry techniczno-eksploatacyjne owijarek czołowych producentów na podstawie przyjętych w pracy kryteriów wyboru oraz ich wag. Końcowa części pracy zawiera strukturę hierarchiczną dla przeprowadzonej oceny oraz podsumowanie.

Słowa kluczowe: AHP – Analytical Hierarchy Process, owijarka, ocena

Introduction

Packaging is an important element of the production process in every enterprise. It performs two important functions: it allows protecting the product during loading and during transport against mechanical damage and corrosion, and also gives it an aesthetic value.

The purpose of the work is to become familiar with the previous process of packaging the finished products in an electrical industry company. Currently, it is done manually by a group of employees who, when wrapping high switchgears, must climb ladders to properly pack products. When packing in the company, the finished products are found in the final assembly hall. They are wrapped by the employees in stretch foil, which is hard and uncomfortable work. The analyses show that the packaging time is far too long and the process itself is chaotic and unprofessional.

The solution of this problem is to improve it by using an automatic pallet wrapping machine, which shortens the packaging time of finished products, significantly improves comfort, employee safety and the organization of the work. The device was selected by comparing several of the most suitable machines for the company, especially taking the most important parameters into account. The AHP method was used to analyze the selection of the most optimal wrapper. The AHP method

can be helpful in making decisions and determining the requirements relevant to the construction of work station [6]. The pallet wrapper is a machine that, using a roll with stretch film and a properly set program in an easy to use control panel, wraps ready-made products for the customer; the device significantly improves the efficiency of the packaging process and reduces the cost of the used materials.

Characteristics of the AHP method

The AHP method was developed by the American scientist Thomas L. Saaty [4, 5] in 1970 and has been constantly modified since then. It is based on mathematical calculations and takes into account the impact of human psychology in its assessment, supporting the making of complex decisions with a fixed number of their variants. It provides a comprehensive and structured way of dividing the problem into factors independent of each other.

The basic assumption of the AHP method is Saaty's statement [4] that human judgements are relative, depending on the assessment approach, their personal characteristics, their role and the value system they profess. The result of such reasoning is a multi-faceted approach to the decision-making problem, manifested in determining the weights of significance (utility) of

individual variants included in the assessment criteria. These decision options are analyzed as part of the comparative assessment. Aggregation of partial grades, taking into account their type, is based on the calculation of the ordered vector of a set of points. The method has been used in many decision situations with different risks of a failure, e.g. in business, industry, statistical decisions [2]. Many companies have developed their own computer programs based on the AHP method, supporting their introduction in a specific application. Using this method you can:

- choose the decision variant,
- assess the quality of e.g. computer software,
- determine the usefulness of safety of technical devices,
- support financial decisions,
- make purchase decisions,
- evaluate construction solutions,
- carry out corrections and organizational changes.

It can be stated that the method is particularly useful [1] in cases of:

- the existence of a hierarchy of evaluation criteria showing different levels of detail, linked to a hierarchy of goals, or expected benefits,
- determining the criteria for assessing options that do not focus on the quantitative but qualitative approach, where the majority of the assessor's (decision-maker)'s ratings are subjective,
- the occurrence of full comparability of variants, i.e. comparison and evaluation are carried out on a set of variants in the same class.
- Making decisions according to the AHP method [1] involves:
- building a hierarchical model - spreading the decision problem and the description of the hierarchy of criteria,
- assessment - comparison of pairs of criteria and decision variants using the relative scale of Saaty dominance,
- setting global and local preferences - mutual priorities (materiality) in relation to criteria and decision options,
- classification of decision variants - ordered due to their participation in meeting the requirements of the primary goal.

Parameters of wrappers of the selected manufacturers

Depending on the specific application in the industry, many types of industrial wrappers are available. The leading ones include the following wrappers:

- disk wrapper ROBOPAC type MASTERPLAT PLUS,
- self-propelled ROBOPAC type ROBOT MASTER PLUS,
- semi-automatic self-propelled SPIDER – PACK,
- vertical ROBOPAC type ECOWRAP PLUS XL.

The basic technical parameters that distinguish industrial wrappers are:

- maximum height of items,
- maximum dimensions of the pallet,
- charging time,
- weight of items on the pallet,
- performance,
- film thickness.

AHP analysis of choosing the wrapper

The general algorithm for proceeding according to the AHP method is presented in Fig. 1. It enables evaluation by expert groups. A large number of assessments of the importance of individual factors may introduce inaccuracies due to a natural discrepancy in the preferences of the assessors. Therefore, in this case it is necessary to calculate – the value of the CI inconsistency index (formula 1). Failure to meet this condition is associated with the reintroduction of the assessment into the comparison matrix to meet the requirement of maintaining object dominance relations - the value of the CR compliance ratio (formula 2). The algorithm consists of several stages. The first is to present the problem and set the criteria. Next, the rating scales (according to Saaty) are determined – by comparing them in the comparison table. The next stage is determining the weight values (priorities) and checking the correctness of the results obtained (matrix consistency test). The final stage is the compilation of results in the form of a hierarchical structure.

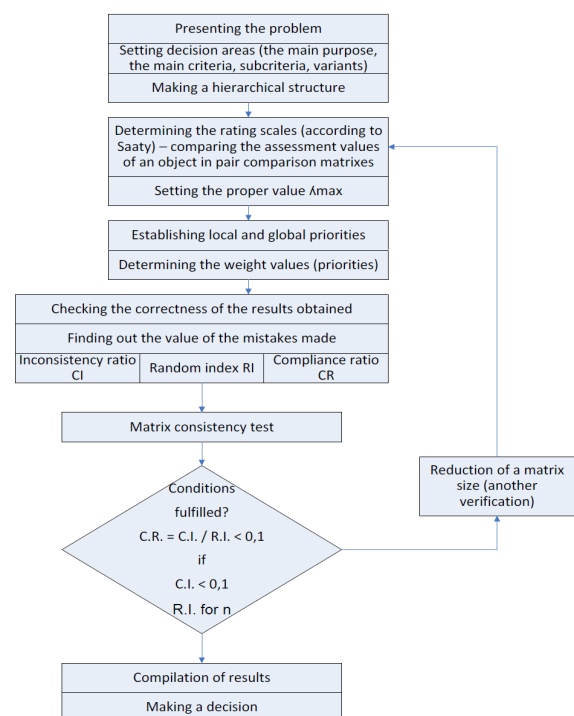

Fig. 1. The algorithm for management according to AHP method applying to a greater number of elements [1]

The paper presents, for example, the choice of an industrial wrapper for packaging products for a company from the energy sector (first stage). Therefore, according to the authors, the most important parameters for this type of application are presented in Table 1.

In the second stage, in order to compare the possible application of industrial wrappers, the following criteria were adopted for assessment: maximum height-KA, maximum dimensions of the pallets-KB, loading time-KC, weight of the item on the pallet-KD.

The comparison of each pair of criteria is recorded in the matrix $N \times N$, where N is the number of elements at a given level. The matrix constructed in this way has the following properties: on the diagonal of the matrix all words $a_{ij} = 1$, above the diagonal $a_{ij} =$ comparison, and below the diagonal the value of the inverse of these comparisons $a_{ji} = 1$. The comparison procedure is presented in Tab. 2.

The procedure for calculating local weights is as follows:

Table 1. Chosen parameters – criteria for industrial wrapping machines [7,8,9,10,11,12,13,14,15]

No.	Disc wrapper ROBOPAC type MASTER-PLAT PLUS	Self-propelled ROBOPAC type ROBOT MASTER PLUS	Semi-automatic self-propelled	Vertical ROBOPAC type ECOWRAP PLUS XL
1. Maximum height of items	2000 mm –optionally 3100 mm	2200 mm – opcjonalnie 2400 mm	SPIDER – PACK	2000 mm – optionally 2400 mm
2. Maximum dimensions of the pallet	1200x1200mm	2200x2200 mm	Without limitations (without the column)	1200x1200mm
3. Charging time	5-8 hours	5-8 hours	8-10 hours (without the column)	10 hours
4. Weight of items on the pallet	2000 kg	Any	Any (without the column)	Any
5. Performance	Up to 25 pallets/hour	Up to 20 pallets/ hour	Up to 20 pallets/ hour	Up to 30 pallets/ hour
6. Film thickness	17-35 μ m	17-35 μ m	35-80 μ m	17-35 μ m

Table 2. A pairwise comparison of parameters – criteria importance [self study]

		KA	KB	KC	KD	KE	KF	total	KA	KB	KC	KD	KE	KF	weight	rating
Maximum height	KA	1.00	2.00	2.00	3.00	3.00	4.00	15.00	0.34	0.19	0.45	0.28	0.40	0.27	0.322	1
Maximum dimensions of the pallet	KB	0.50	1.00	0.33	0.50	0.50	2.00	4.83	0.17	0.10	0.07	0.05	0.07	0.13	0.098	5
Charging time	KC	0.50	3.00	1.00	4.00	2.00	3.00	13.50	0.17	0.29	0.23	0.37	0.27	0.20	0.253	2
Weight of an item on the pallet	KD	0.33	2.00	0.25	1.00	0.50	3.00	7.08	0.11	0.19	0.06	0.09	0.07	0.20	0.120	4
Performance	KE	0.33	2.00	0.50	2.00	1.00	2.00	7.83	0.11	0.19	0.11	0.18	0.13	0.13	0.145	3
Film thickness	KF	0.25	0.50	0.33	0.33	0.50	1.00	2.91	0.09	0.05	0.07	0.03	0.07	0.07	0.062	6
TOTAL		2.91	10.50	4.41	10.83	7.50	15.00	51.15							1.000	

- adding up the scores for each column and then saving them in the sum column,
- each grade in columns KA to KG is divided by the sum of the grades for this column and the result is entered in the following columns, as appropriate,
- calculating the weight for a selected criterion is made by adding up the values recorded in the fields from KA to KG, then the sum obtained is divided by the number of elements and the result is saved in the weight field,
- checking the correctness of calculations by adding weights of all elements of a given level (the sum of weights is always equal to 1); when using the AHP method, it should also be checked that the results obtained do not violate the principle of constancy of preferences; for this purpose, the inconsistency factor λ_{max} must be calculated. [4].

The choice of criteria is always dictated to a large extent by the availability of information on the selected wrappers and the significance of parameters, which is why the authors based their decision on the most important factors of choosing an industrial wrapper quoted in chapter 3 [3].

Checking the correctness of the results obtained

Using the algorithm of the AHP method, check in the next step whether the results obtained do not violate the principle of constancy of preferences (checking the correctness of the results obtained). For this purpose, the inconsistency factor λ_{max} was calculated (Table 3). In the Saaty method, the necessary condition is to obtain the required conformity of assessments, expressed by the value of the compatibility ratio of the CI comparison matrix (formula 1) and the CR compliance ratio (formula 2), whose value should not exceed 0.1.

Table 3. Checking the correctness of the results obtained [own study]

Criteria	Total value	Weights	Inconsistency index
KA	2.91	0.32	0.94
KB	10.50	0.10	1.03
KC	4.41	0.25	1.12
KD	10.83	0.12	1.30
KE	7.50	0.14	1.09
KF	15.00	0.06	0.93
Total			6.40

The following procedure is used to check that the preferences are stable. The inconsistency index for individual criteria is calculated as the product of the sum of the scores and weights of individual criteria.

After substituting the values of $\lambda_{max} = 6.40$ and $n = 6$ into the formula (1), the values of the compliance index $CI = 0.0642$ and the compliance ratio $CR = 0.0518$ calculated according to the formula (2) were obtained.

$$CI = \frac{\lambda_{max} - n}{r(n-1)} = 0,0642 \quad (1)$$

where

n – the value of a random index according to Saaty

($n = 6$),

r – the matrix index ($r = 1.24$).

Table 4. The value of „r” index for the size of an array „n” [4]

n	1	2	3	4	5	6	7	8	9	10
r	0.0	0.0	0.58	0.9	1.12	1.24	1.32	1.41	1.45	1.49

and:

$$CR = \frac{CI}{r} = 0.0518 \quad (2)$$

In the above example, two conditions are met; $CI < 0.1$ and $CR < 0.1$, i.e. the preference stability has not been affected. Then the weights were calculated and a ranking was established for each of the adopted parameters - the criteria of an industrial wrapper. In Tab 5-7, in accordance with the procedures for comparing the criteria given above, for example, the method of creating a partial

Table 5. A chosen parameter, „maximum dimensions of the pallet” [one’s own study based on materials 7-15]

Industrial wrappers	Maximum pallet dimensions
Disc wrapper ROBOPAC type MASTERPLAT PLUS	1200x1200 mm
Self-propelled ROBOPAC type ROBOT MASTER PLUS	2200x2200 mm
Semi-automatic self-propelled SPIDER – PACK	Without limitations (without the column)
Vertical ROBOPAC type ECOWRAP PLUS XL	1200x1200 mm

Table 6. A pairwise comparison for the „maximum dimensions of the pallet” [own study]

	WA	WB	WC	WD	WE	WF	total	WA	WB	WC	WD	WE	WF	weight
WA	1.00	0.33	3.00	3.00	3.00	3.00	13.33	0.19	0.12	0.34	0.26	0.18	0.36	0.242
WB	3.00	1.00	2.00	3.00	4.00	3.00	16.00	0.56	0.36	0.23	0.26	0.24	0.36	0.336
WC	0.33	0.50	1.00	2.00	3.00	0.50	7.33	0.06	0.18	0.11	0.18	0.18	0.06	0.128
WD	0.33	0.33	0.50	1.00	3.00	0.50	5.66	0.06	0.12	0.06	0.09	0.18	0.06	0.094
WE	0.33	0.25	0.33	0.33	1.00	0.33	2.57	0.06	0.09	0.04	0.03	0.06	0.04	0.053
WF	0.33	0.33	2.00	2.00	3.00	1.00	8.66	0.06	0.12	0.23	0.18	0.18	0.12	0.147
TOTAL	5.32	2.74	8.83	11.33	17.00	8.33	53.55							1.000

Table 7. Checking the correctness of the results obtained [own study]

Maximum pallet dimensions			
Criteria	Total value	Weights	Inconsistency index
WA	5.32	0.24	1.29
WB	2.74	0.34	0.92
WC	8.83	0.13	1.13
WD	11.33	0.09	1.06
WE	17.00	0.05	0.90
WF	8.33	0.15	1.22
Total			$\lambda_{max} = 6.53$

ranking for the „maximum pallet dimensions” criterion was presented

$$CI = \frac{\lambda_{max} - n}{r(n - 1)} = 0.0856 \quad (3)$$

and:

$$CR = \frac{CI}{r} = 0,0691 \quad (4)$$

The final stage of assessment and selection of an industrial wrapper according to the AHP method is the

Table 8. Checking the correctness of the results obtained [own study]

Industrial wrappers		Maximum height	Maximum pallet dimensions	Maximum pallet dimensions	Weight of an item on the pallet	Performance	Film thickness	Total	Rating
ROBOPAC type MASTERPLAT PLUS	WA	0.32	0.24	0.15	0.38	0.22	0.07	1.36	1
ROBOPAC type ROBOT MASTER PLUS	WB	0.13	0.34	0.08	0.14	0.39	0.06	1.14	2
SPIDER-PACK	WC	0.17	0.13	0.14	0.09	0.06	0.19	0.77	4
ROBOPAC type ECOWRAP PLUS XL	WD	0.05	0.09	0.14	0.06	0.11	0.36	0.83	3

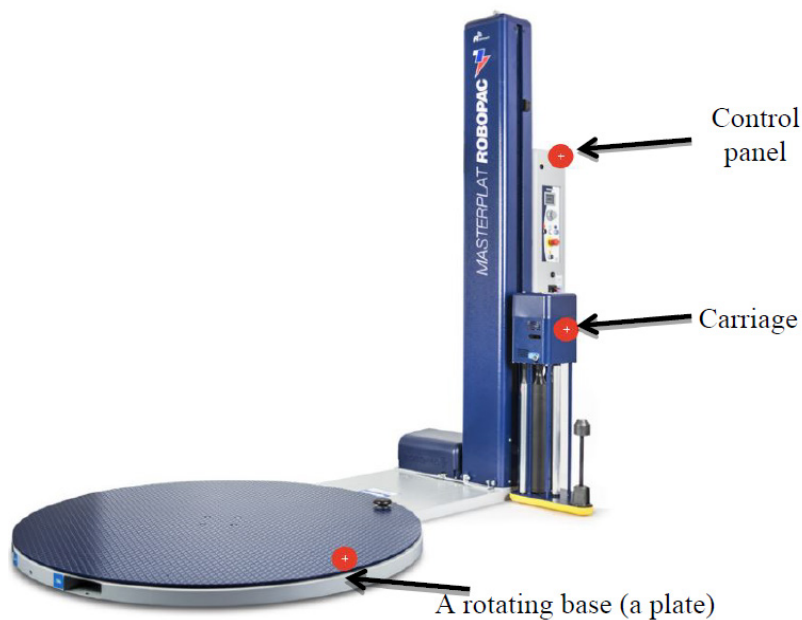

Fig. 2. A ROBOPAC disk wrapping machine MASTERPLAT PLUS

development of a hierarchical structure. The results obtained are presented in Tab. 8.

The presented analysis shows that the ROBOPAC MASTERPLAT PLUS disc wrapping machine should be selected [Fig. 2].

Partly automated packing process

The packaging process with the applied Robopac Masterplat plus disc wrapping machine will take place in the following order:

- loading the product on a pallet truck,
- placing the product on the wrapper,
- applying polystyrene corners,

- starting the program in the control panel,
- transporting the wrapped object by forklift to the warehouse of products ready for shipment to the customer.

An additional innovation is the use of polystyrene corners, which significantly better protect finished products during loading and transport. To save time of packing products, both polystyrene corners and rolls with stretch foil will be located on individual shelves at the wrapping machine. Below is an illustrative packaging process in one of the halls in a company using a ROBOPAC MASTERPLAT PLUS disk wrapper in 3D structure using the SolidWorks program [Fig. 3].

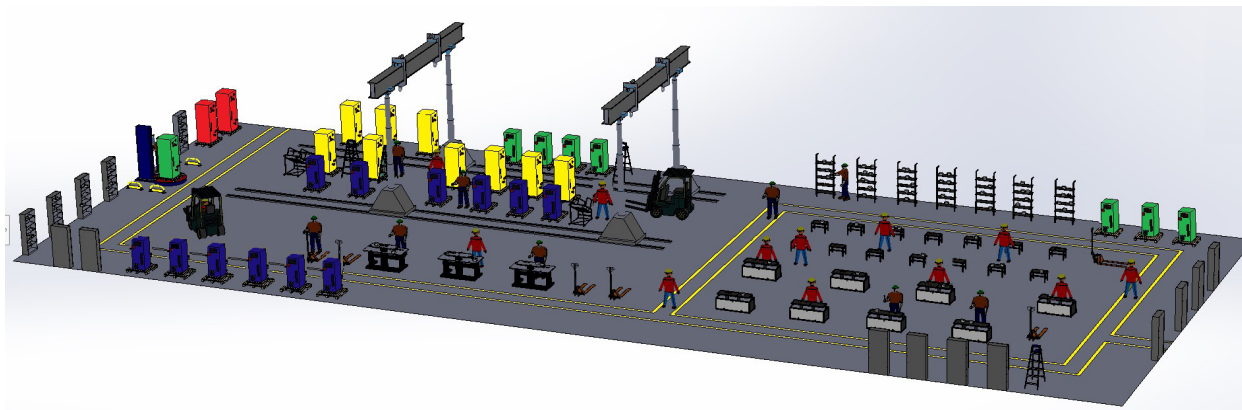

Fig. 3. 3D hall structure made in SolidWorks

The improved process of packing finished products by using a ROBOPAC MASTERPLAT PLUS disk wrapper made in a 3D structure (Fig. 4), which allows a detailed presentation of the work process. All products will be transported by forklifts to the wrapping position; the employee will set parameters in the control panel and control the operation of the machine. Packaged products will be transported to the warehouse or directly to the customer. A space was created for the wrapping machine in one of the halls in the energy company (Fig. 4). The machine meets the ergonomic requirements. To ensure work safety, protective barriers are attached around the device. To set the parameters wrapped in the control panel and to control the entire work process of the device, only one properly trained employee is sufficient.

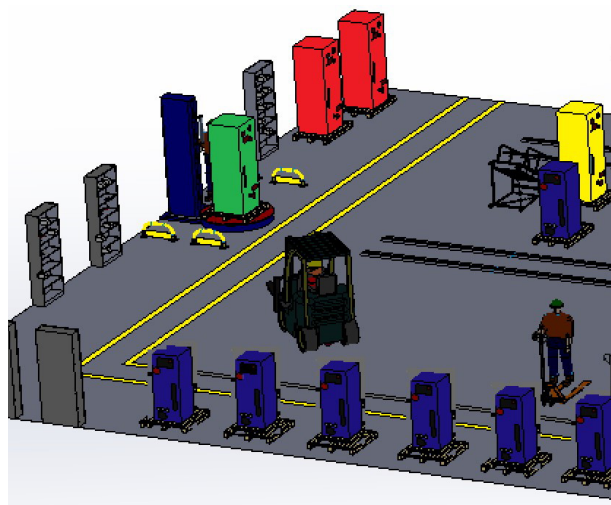

Fig. 4. An approximate packaging process in the hall in 3D made in SolidWorks

Conclusions

The study attempted to show that the AHP method allows evaluating the decision variants within one of their product classes. A formal approach is used to acquire and process expert assessments. It is a flexible method and can be adapted to various classes of the examined objects, including their specifications.

The obtained results indicate that on the basis of parameters - criteria specified by experts, the ROBOPAC type MASTERPLAT PLUS disk wrapping machine should be selected, followed by ROBOPAC type ROBOT MASTER PLUS. Relative values obtained as a result of calculations indicate that the advantage of the ROBOPAC MASTERPLAT PLUS wrapper over the others is large. This is the latest solution of ROBOPAC, thanks to which the operator operating the wrapper has an access to each side of the machine. In addition, it is equipped with a thin plate with a thickness of 30 mm, increasing safety at work and facilitating loading onto the wrapping plate, and the system of patented discs significantly increases the reliability of the machine.

The authors intend to analyze the advantages and disadvantages of the AHP method in the construction of more complex technological processes. To convince themselves that this method is justified for use by engineers, the authors intend to analyze more complicated assembly technological processes (choice of technological variant).

References

- [1] Downarowicz O., Krause J., Sikorski M., Stachowski W. 2000. Zastosowanie metody AHP do oceny i sterowania poziomem bezpieczeństwa złożonego obiektu technicznego, 7-42. Wydawnictwo Politechniki Gdańskiej.
- [2] Grzegorzewski P. 2006. Wspomaganie decyzji w warunkach niepewności, metody statystyczne dla nieprecyzyjnych danych, 53. Warszawa: Akademicka Oficyna Wydawnicza EXIT.
- [3] Knosala R. 2005. Komputerowo zintegrowane zarządzanie (t. 1 i 2), 43. Warszawa: WNT.
- [4] Saaty T. L. 1994. Fundamentals of Decision Making and Priority Theory with The Analytic Hierarchy Process, 55. Pittsburgh, PA: RWS Publications.
- [5] Saaty T. L. 1999. Fundamentals of the Analytic Network Process, 67. Pittsburgh, PA.
- [6] Żurek J. 2006. Podstawy robotyzacji, 150. Wydawnictwo Politechniki Poznańskiej.
- [7] <http://www.vincent.pl/maszyny-pakujace/owijarki-do-palet/ramieniowe/Masterwrap-XL-FR/> [Accessed: 15.07.2018 and 20.11.2018].
- [8] <http://www.vincent.pl/maszyny-pakujace/owijarki-do-palet/talerzowe/masterplat-plus/> [Accessed: 15.07.2018 and 20.11.2018].
- [9] <http://www.vincent.pl/maszyny-pakujace/owijarki-do-palet/samojezdne/Robot-Master/> [Accessed: 15.07.2018 and 20.11.2018].
- [10] http://www.robopac.com/UK/products/Vertical_stretch_wrapping_machines/turntables/masterplat [Accessed: 15.07.2018 and 20.11.2018].
- [11] http://www.robopac.com/UK/products/Vertical_stretch_wrapping_machines/Self_propelled_Robots/robot_master_plus [Accessed: 15.07.2018 and 20.11.2018].
- [12] http://www.robopac.com/UK/products/Vertical_stretch_wrapping_machines/rotating_arm/masterwrap_plus_xl_fr [Accessed: 15.07.2018 and 20.11.2018].
- [13] <https://e-promag.pl/katalog/Polautomatyczna-samojezdna-owijarka-do-palet-SPIDER-PACK,1459.html> [Accessed: 15.07.2018 and 20.11.2018].
- [14] <http://www.styromax.com.pl/oferta.php?kategoria=3> [Accessed: 10.12.2018].
- [15] <http://2mpack.pl/narozniki-styropianowe/> [Accessed: 10.12.2018].
- [16] <https://www.vincent.pl/maszyny-pakujace/owijarki-do-palet/talerzowe/MASTERPLAT-PLUS-LP/> [Accessed: 10.12.2018].

dr inż. Robert Cieślak
Państwowa Wyższa Szkoła Zawodowa w Koninie
ul. Wyszyńskiego 35, 62-510 Konin, Polska
e-mail: robert.cieslak@konin.edu.pl

dr inż. Katarzyna Peta
Politechnika Poznańska
Wydział Inżynierii Mechanicznej
ul. Piotrowo 3, 60 - 965 Poznań, Polska
e-mail: katarzyna.peta@put.poznan.pl

dr inż. Marcin Suszyński
Politechnika Poznańska
Wydział Inżynierii Mechanicznej
ul. Piotrowo 3, 60 - 965 Poznań, Polska
e-mail: marcin.suszynski@put.poznan.pl

dr inż. Marcin Wiśniewski
Politechnika Poznańska
Wydział Inżynierii Mechanicznej
ul. Piotrowo 3, 60 - 965 Poznań, Polska
e-mail: marcin.wisniewski@put.poznan.pl

inż. Julia Kałużna
Absolwentka PWSZ w Koninie

SELECTION OF JOINTS FOR TESTING A FATIGUE LIFE OF AVIATION RIVETS

Dobór połączeń do badania trwałości zmęczeniowej nitów lotniczych

Jan GODZIMIRSKI ORCID 0000-0003-1593-2057
Marek ROŚKOWICZ ORCID 0000-0003-0501-0622

DOI: 10.15199/160.2020.2.3

Abstract: During the operation of aircraft, rivets sometimes loosen, what requires their replacement. The use of original rivets in repairs is troublesome and sometimes impossible due to the lack of access to the interior of the airframe structure. In this case, blind rivets should be used, provided that they have greater or equivalent strength to the original rivets. The aim of the study was to compare the statistical strength and fatigue life of the rivets that are usually used in the construction of the Mi-24 airframe and blind rivets that can be their substitutes. The object of the study included one-sided rivets: titanium core threaded MBF2110AB-05-15 with round head (4.2 mm diameter) and one-side Huck rivet with an extruded core (diameter 4.8 mm). The properties of these rivets were compared with those of ordinary 3558A-4-10 mushroom rivets manufactured from the W65 alloy used in the construction and repair of Mi24 helicopters. Comparative tests of rivet shear strength, head and end pull-off strength and fatigue life were carried out. An important problem turned out to be the selection of such a sample for fatigue tests, so that rivets and not the plates connected with them were destroyed by fatigue. These requirements were met by single strap samples in which C profile was strap.

Keywords: rivet joints, blind rivets, equivalent strength, fatigue strength

Streszczenie: W trakcie eksploatacji statków powietrznych dochodzi czasami do obluźniania nitów, co wymaga ich wymiany. Stosowanie w naprawach oryginalnych nitów jest kłopotliwe, a czasami niemożliwe ze względu na brak dostępu do wnętrza struktury płatowca. W tym wypadku należy zastosować nity jednostronne pod warunkiem, że będą one miały większą lub równoważną wytrzymałość z nitami oryginalnymi. Celem prowadzonych badań było porównanie wytrzymałości statycznej i trwałości zmęczeniowej nitów zwykłych stosowanych w budowie płatowca Mi-24 oraz nitów jednostronnych mogących być ich zamiennikami. Obiektem badań były nity jednostronne: tytanowe, rdzeniowe nawlekane MBF2110AB-05-15 z łbem okrągłym (średnic 4,2 mm) jednostronne Hucka z rdzeniem wyciąganym (średnica 4,8 mm). Właściwości tych nitów porównywano z właściwościami nitów zwykłych grzybkowych 3558A-4-10 wytwarzanych ze stopu W65, stosowanych w budowie i naprawach śmigłowców Mi24. Przeprowadzono badania porównawcze wytrzymałości nitów na ścinanie, wytrzymałości na odrywanie łbów i zakuwek oraz trwałości zmęczeniowej. Istotnym problemem okazał się dobór takiej próbki do badań zmęczeniowych, aby zniszczeniu zmęczeniowemu ulegały nity, a nie łączone nimi blachy. Wymagania te spełniły próbki jednonakładkowe, w których nakładką był ceownik.

Słowa kluczowe: połączenia nitowe, nity jednostronne, równoważna wytrzymałość, wytrzymałość zmęczeniowa

Introduction

Airframe structures of aircraft are joined mainly by cold riveting methods due to the materials from which they are made, that is, from aluminum alloys of the AW 2xxx group [7, 8]. The production process mainly uses ordinary rivets made of aluminum alloys (e.g. Polish PA25 or Russian alloy W 65 with shear strength $R_t = 245$ MPa) with various types of heads. In heavily loaded connection nodes, so-called rivets with increased shear strength made of 30GHS steel or titanium are used, which are essentially fitted pins. Blind rivets (one-sided) are also occasionally used in places where there is no access to the hold-on (bolster) in the riveting process [2].

During aircraft operation, rivets are sometimes loosened, what requires replacement, as tightening

loose rivets is generally unacceptable, and damage to the skin, which requires the installation of the patches connected to the airframe structure by riveting. The use of original rivets in repairs is troublesome and sometimes impossible due to the lack of an access to the interior of the airframe structure. In this case, blind rivets should be used, provided they have equivalent or greater strength with the original rivets. Various blind rivets are available on the market, but most of them do not even meet the criterion of equivalent static shear strength. Considering the operational loads of helicopter airframes, besides short-term strength, fatigue strength of rivets and joints made with their use is equally important and even more important [5].

The latest blind rivets produced for aviation are stranded core rivets made of titanium alloys or steel. Due

to the materials they are made of, they should be more durable than ordinary duralumin rivets. However, the admission of such rivets for the repair of military aircraft requires evidence that they will meet the requirement of equivalent strength and durability, which shall mean:

- not less static strength,
- no lower fatigue life of rivets,
- no less fatigue durability of joints made with these rivets,
- corrosion resistance, especially electrolytic.

The purpose of the research was to compare the static strength and fatigue life of ordinary rivets used in the construction of the Mi-24 airframe and blind rivets that could be their substitutes.

The objects of the study were blind rivets:

- titanium threaded core MBF2110AB-05-15 with round head (diameter 4.2 mm)
- one-sided Huck rivets with pull-out core (diameter 4.8 mm)

The properties of these rivets were compared with those of ordinary 3558A-4-10 mushroom rivets manufactured from the W65 alloy used in the construction and repair of Mi-24 helicopters. The strength of riveted joints has been devoted to many publications, whose comprehensive review and analysis are contained in [6]. In the research presented in this article, the main attention was devoted to the fatigue strength of the rivets themselves.

Static testing

Five single-overlap riveted samples were made with use: standard rivets 3558A-4-10 and blind rivets MBF2110AB-05-15, as well as 5 single strap samples connected with Huck rivets. Single-overlap samples were created by connecting cuboid elements with dimensions 100x25x2 mm with two rivets. Single-overlap and single strap connections are made of plated AW 2024T3 alloy. The length of the connection overlap was 32 mm and the assumed rivet spacing corresponded to the assembly scheme of 10-12-10 mm. Plain rivets were pressed up in the press.

Single strap samples with Huck rivets were prepared with a 4 mm thick strap (80x25x4 mm) combining it with four rivets with 100x25x2 mm elements. The diagram of the connections used is presented in Fig. 1.

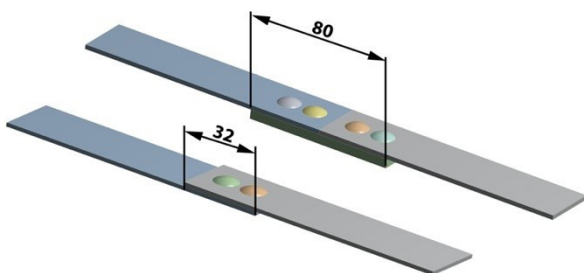

Fig. 1. View of the single-overlap and single strap samples

Strength tests were carried out on the ZD10 testing machine and the values of destructive forces for single-overlap and single strap joints are presented in Table 1.

Table 1. Load capacity of single-overlap and single strap joints [N] and rivets shear strength

Sample number	3558A-4-10 ordinary rivets	MBF2110AB-05-15	Huck rivets (single strap joint)
1	7350	11600	9500
2	7500	11700	9700
3	7500	11600	9700
4	7500	11400	9600
5	7350	11700	9500
Arithmetic average	7440±102	11600±151	9600±124
Shear strength of rivet	$R_t = 296 \text{ MPa}$	$R_t > 419 \text{ MPa}$	$R_t = 265,4 \text{ MPa}$

Destruction of joints connected with plain and Huck rivets consisted of cutting the rivets (Fig. 2A), and joints connected with blind rivets by tearing off the heads, ovalization of the holes and plastic bending of the joined elements (Fig. 2B).

In the tests of static strength of connections with Huck rivets, a load capacity was obtained, which corresponds to shear strength $R_t = 265.4 \text{ N}$, i.e. it is comparable with standard 3558A-4-10 rivets.

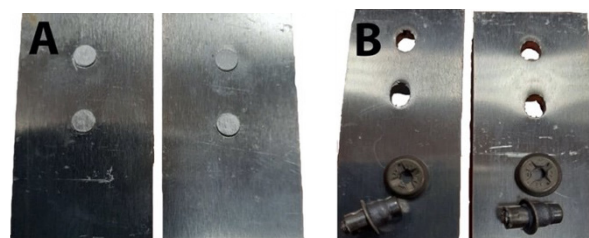

Fig. 2. Destruction of standard and blind rivets in the static strength test

Because the blind rivets have a different head and end cap structure than ordinary rivets, the tensile strength of the head and end rivets has been tested. The method used was based on riveting two C-profiles with an appropriate wall thickness (Fig. 3) and then loading them in a testing machine with the use of supports and a load transmitting element.



Fig. 3. Sample for testing the tensile strength of rivet heads

Five strength tests of the ordinary rivets were carried out, obtaining similar strength results: 5700, 5250, 5400, 5450 and 5300 N (average value of breaking force 5420 ± 218 N). Destruction of the rivet consisted not in breaking off the head, but in cutting it off (Fig. 4).



Fig. 4. Mechanism of rivet head destruction

In the case of MBF2110AB-05-15 blind rivets, the destruction consisted of breaking the threaded shank (Fig. 5) at 6900, 6800 and 6800 N.



Fig. 5. Destruction of the MBF2110AB-05-15 rivet in a pull-off test

The destruction of Huck rivets occurred at 2300 and 2250 N and consisted in breaking the sleeve connected to the head (Fig. 6).



Fig. 6. Destruction of Huck rivet in an attempt to detach the head

Due to the low head tensile strength, Huck rivets have been eliminated from further testing.

Fatigue tests

Selection of sample for testing fatigue life of rivets

The use of single-overlap samples in fatigue tests results in determining the fatigue life of the joint, not the rivets, because the joined sheets are damaged due to fatigue bending (Fig. 7) [8].

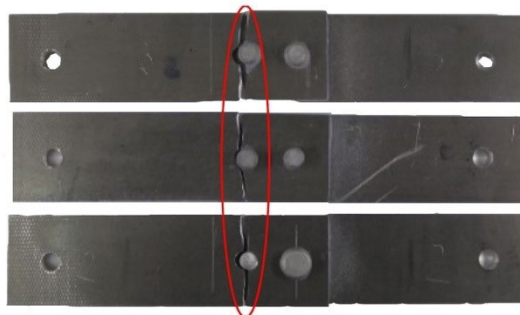

Fig. 7. Fatigue destruction of riveted single-overlap samples [1]

In order to eliminate bending, the suitability of double-overlap sample (Fig. 8) connected with one rivet was tested for fatigue testing.



Fig. 8. Double-overlap sample

Double-lap samples (with an overlap length of 20) connected with one rivet were prepared again from cuboid elements with dimensions of $100 \times 25 \times 2$ mm and subjected to fatigue tests with a frequency of 20 Hz. Literature data shows that for load frequencies of 0.15 Hz and 40 Hz, the test results do not show differences regarding fatigue life of samples made of 2024-T3 alloy [5, 6]. Also, tests conducted on a three-row rivet joint made of 2024-T3 material at two different load frequencies 1 Hz and 10 Hz confirmed the lack of the test frequency on fatigue life of riveted joints [4].

In order to obtain rivet destruction with a number of cycles less than 500,000 cycles, the experimental tests changed the load range successively, increasing the average value of amplitude in the cycle. For the 1st range, extreme load values were equal to $F_{max} = 4500$ N and $F_{min} = 3500$ N, for the 2nd 5000 and 4000 N respectively, for the 3rd 5400 and 4000 N and for the 4th 6000 and 4000 N.

At the largest load range, the sample was destroyed after 89 238 cycles, but not the rivet, but the central plate. To reduce the stress in the joined elements in the next sample, 32 mm wide sheets were used. The sample was subjected to fatigue loading in the range of $F_{max} = 6000$ N and $F_{min} = 4000$ N. After 91.568 cycles, as in the case of a 20 mm wide sample, the central plate cracked. The shape of the crack and the deformation of the sheet (Fig. 9) show that the reason for such damage was exceeding the allowable pressures, whose value was: 731.7 MPa.



Fig. 9. Fatigue cracking of the central sheet of a double-overlap 32 mm wide sample

In order to eliminate the problem of excessive surface pressure, it was decided to use a larger number of rivets and a single strap asymmetrical connection (Fig. 10), in which shear stresses in the rivet shank are similar to those in a double-overlap sample with one rivet, and the surface pressures were twice as low. Such a sample also better reproduces the work of a skin supported on a longitudinal half-shell structure.



Fig. 10. Asymmetrical single strap sample

The sample was subjected to fatigue loading in the IV range, i.e. $F_{max} = 6000$ N and $F_{min} = 4000$ N. After 260 812 cycles, the strap fatigue cracked (Fig. 11). Therefore, it was decided to replace the flat strap with a 25x15x2 mm dural channel bar (Fig. 12) in order to cause fatigue damage of the rivets.

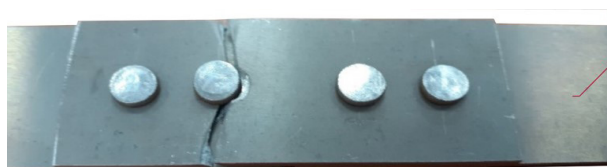

Fig. 11. Fatigue crack of flat cover plate

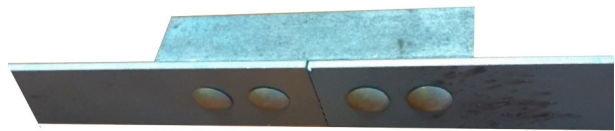

Fig. 12. Single strap sample with C-profile

The sample was subjected to fatigue in the range of $F_{max} = 6000$ N and $F_{min} = 4000$ N. After 819,000 cycles, the load $F_{max} = 6600$ N and $F_{min} = 4000$ N was increased and the sample was subjected to further testing. After completing an additional 37,610 cycles, the rivets on one side of the strap were damaged (Fig. 13).

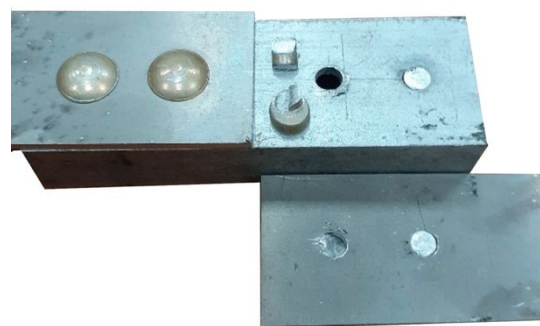

Fig. 13. Nature of fatigue failure of rivets of a single-strap sample with C-profile

The next single-strap sample with C-profile was subjected to fatigue loading in the range of $F_{max} = 6600$ N and $F_{min} = 4000$ N. After 391, 785 fatigue cycles, fatigue cutting of the rivets occurred (Fig. 14).

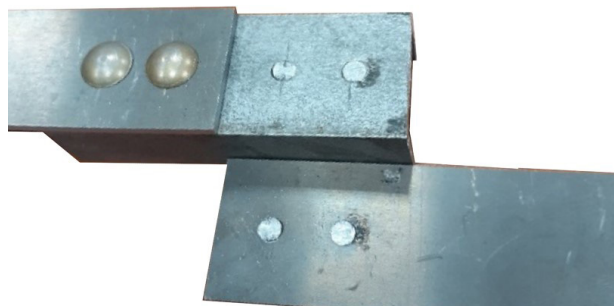

Fig. 14. The nature of fatigue failure of a single-strap sample with C-profile loaded in the range $F_{max} = 6600$ N and $F_{min} = 4000$ N

The conducted tests allowed accepting the conditions of comparative fatigue tests of ordinary rivets and their blind rivet substitutes. In order to obtain the destruction of the rivets, and not the joined sheets, it was decided to use single-strap samples in which the strap will be a C-profile. It was decided to load the samples in the same range $F_{max} = 6600$ N and $F_{min} = 4000$ N with a frequency of 20 Hz, and the tests lead to at least 500,000 load cycles.

A single-strap sample with C-profile connected with round head MBF2110AB-05-15 titanium rivets had fatigue life of 610,000 cycles and the test was discontinued. Computed tomography (Fig. 15) tests showed that in the sample with round head MBF2110AB-05-15 titanium rivets, loose connection, decalibration of holes and displacement of the connected elements.

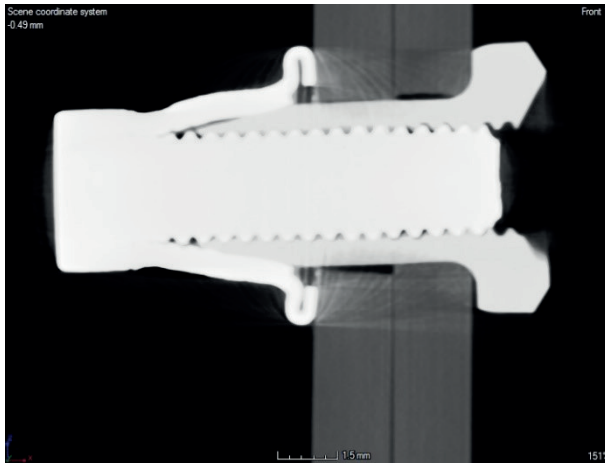

Fig. 15. Sample with MBF2110AB-05-15 titanium rivets after 610,000 load cycles

Conclusions

The tested blind rivets MBF2110AB-05-15 have higher shear strength compared to the rivets to be replaced with them, and Huck rivets about 10% lower. The latter, due to the low head pull-off strength, cannot be substitutes for the ordinary rivets.

Preliminary tests allowed selecting a sample for comparative tests of fatigue life of ordinary rivets and strength-equivalent blind rivets - a single-strap sample with a strap in the form of a C-profile.

MBF2110AB-05-15 titanium blind rivets with round head are also characterized by greater fatigue life compared to standard 3558A-4-10 rivets.

Comparative fatigue tests should be carried out to check how blind rivets affect the fatigue life of the sheets

to be joined. Such tests can be carried out on single-overlap samples.

References

- [1] Adameczek A., Godzimirski J. 2017. „Optymalizacja wytrzymałości połączeń klejowo-nitowych”. *Technologia i Automatykacja Montażu* 96(2): 7-12.
- [2] Gąsior J., Komorek A., Rośkowicz M., Tkaczuk S. 2018. „Ocena możliwości zastąpienia nitów typu solid w połączeniach konstrukcji lotniczych”. *Technologia i Automatykacja Montażu* 100(2): 53-56.
- [3] Klaassen W. 1955. The fatigue diagram for fluctuating tension of single lap joints of clad 24 ST and 75 ST aluminum alloy with 2 rows of 17 S rivets. Report NLR M.1980. NLR, Amsterdam.
- [4] Müller R.P.G. 1995. An experimental and analytical investigation on the fatigue behavior of fuselage riveted lap joints. The significance of the rivet squeeze force, and a comparison of 2024-T3 and Glare 3. Ph.D. thesis, TU Delft. The Netherlands: TU Delft.
- [5] Schijve J. 2009. *Fatigue of Structures and Materials*. Springer Netherlands.
- [6] Skorupa A., Skorupa M. 2012. *Riveted Lap Joints in Aircraft Fuselage - Design, Analysis and Properties*. Springer Dordrecht Heidelberg New York London.
- [7] Szulżenko M.N., Mostowoj A.S. 1970. *Konstrukcja samolotów*. Warszawa: WKŁ.
- [8] Szymczyk E. 2016. *Numeryczna analiza zjawisk lokalnych w połączeniach nitowych konstrukcji lotniczych*. Warszawa: WAT.

prof. dr hab. inż. Jan Godzimirski
Wydział Mechatroniki i Lotnictwa Wojskowej Akademii Technicznej
ul. gen. Sylwestra Kaliskiego 2
00-908 Warszawa 46, Polska
e-mail: jan.godzimirski@wat.edu.pl

dr hab. inż. Marek Rośkowicz
Wydział Mechatroniki i Lotnictwa Wojskowej Akademii Technicznej
ul. gen. Sylwestra Kaliskiego 2
00-908 Warszawa 46, Polska
e-mail: marek.roskowicz@wat.edu.pl

PORTAL INFORMACJI TECHNICZNEJ
największa baza publikacji on-line
www.sigma-not.pl

IMPORTANCE AND CONTROL OF GEOMETRIC AND KINEMATIC ACCURACY IN PRECISION MACHINING OF PARTS IN ASSEMBLY OPERATION ASPECT

Znaczenie geometrycznej i kinematycznej kontroli dokładności maszyn w dokładnej obróbce części w aspekcie operacji montażu

Damian BASARA
Leszek SKOCZYLAS

ORCID 0000-0001-9342-4790
ORCID 0000-0002-2714-7155

DOI: 10.15199/160.2020.2.4

Abstract: This paper presents general characteristics of methods for measuring kinematics and geometry of CNC machines. Implementation of the selected control methods at numerical centres is shown. The mentioned centres are a part of flexible production lines used for the production of parts in the aviation industry used to assembly power transmissions that require high-precision components. Adapted control methods allow automatic planned mode or forced mode to test the machine's suitability for the machining process. The assessment applies to geometry and kinematics of the CNC machine.

Keywords: CNC machine, FMS, control of accuracy, tests of machines

Streszczenie: W pracy przedstawiono ogólną charakterystykę metod pomiaru kinematyki i geometrii maszyn CNC. Pokazano implementację wybranych metod na centrach numerycznych. Wspomniane centra są częścią elastycznych linii produkcyjnych wykorzystywanych do produkcji podzespołów w przemyśle lotniczym, używanych do montażu przekładni mocy wymagających precyzyjnych komponentów. Dostosowane metody kontroli pozwalają - w trybie automatycznym lub wymuszonym - przetestować zdolność maszyny do procesu obróbki. Ocena dotyczy geometrii i kinematyki maszyny CNC.

Słowa kluczowe: maszyna CNC, elastyczne systemy produkcyjne, kontrola dokładności, testy maszyn

Introduction

Manufacturers of aviation parts are facing growing requirements related to delivery times, low prices and a high quality of finished products. To meet those needs, solutions in the form of flexible manufacturing systems (FMS), are increasingly used. One of the important aspects accompanying the production on FMS lines is the quality of machining, more precise mapping of the programmed shape in accordance with the quality requirements. When the machine is delivered to the user, the manufacturer performs tests for confirming its accuracy. The mentioned accuracy changes or degrades over time and requires constant diagnosis. The issues discussed in the article refer to the accurate machining of aviation parts that function in the assembly and are components in manufacturing assembly operations. For these parts, assembly operation is determined by the accuracy of the machining operations, where the dimensions must be kept within the assumed tolerance. Checking accuracy of machining machines is the subject of many studies [5, 7, 8, 11]. In the traditional manufacturing system, on conventional or numerical machines, the operator performs measurements and

dimensional corrections during the process. These activities in the case of spatially complex parts (aviation power transmission housings), which are produced in the FMS system using five-axis machines, is complicated and often impossible due to technological conditions and EHS (environment, health and safety). The need for geometrical and kinematic control of the accuracy of the machine on which the part is produced, results from the machine zero point shift occurring during manufacture. This results in a shift in the position of the geometrical parts machined in the given operation relative to the base surface. In machining parts, which in the undertaken case are elements of the power transmission gearbox, such a shift is unacceptable because it is related to the occurrence of relative positioning errors visible during assembly operations, often without the possibility of their removal. These are, for example, errors in the setting of the axis of the mating shafts that prevent the product from functioning properly. Thus, the only way to ensure correct functioning of the product and its assembly is to accurately manufacture the components of the assembly. Ensuring high machining accuracy requires the use of control and supervision of machining operations. The use

of existing accuracy control solutions on the market is associated with a relatively long machine downtime.

The article presents the most commonly used methods for diagnosing geometry and kinematic errors of CNC machines and also solutions resulting from research and implementation work, operating in automatic mode on FMS lines, which are used to assess the machine's suitability for the machining process.

Used methods for measuring machines accuracy

• Measurement of geometry using reference instrumentation

One of the basic tests enabling the assessment of the machines geometry condition are measurements made in accordance with the provisions of international standards ISO230 and ISO10791. They contain, *inter alia*: checking the straightness of motion in all linear axes in the possible planes of the basic machine system, perpendicularity between linear axes and test of angular linear motion deviations. Fig. 1. shows diagram for measuring the straightness of the X axis movement in the XY and ZX planes on a horizontal 5 axis CNC machine.

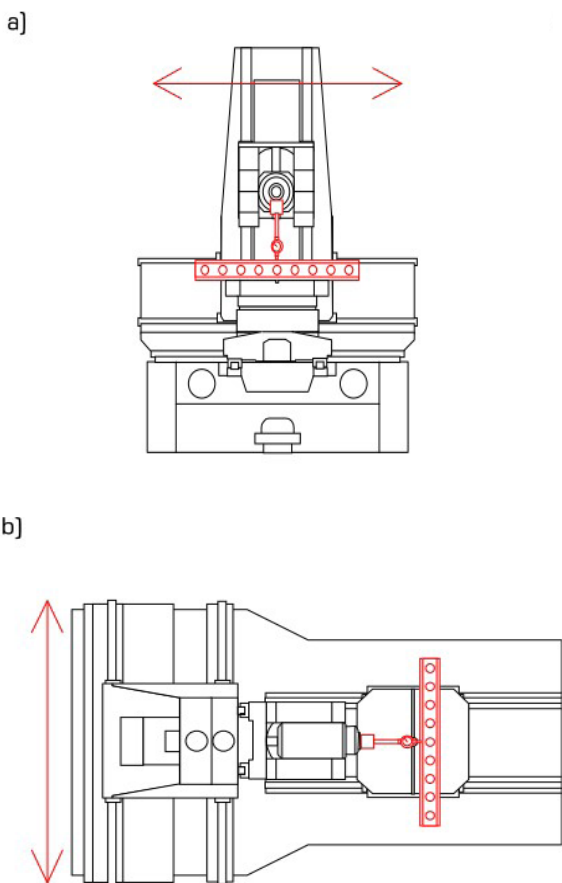

Fig. 1. Checking of straightness of the X-axis motion (ISO 10791-1 - G1): a) in the vertical XY plane (EYX) b) in the horizontal ZX plane (EZX) [2]

For this type of measurement, there are used reference instrumentations such as: granite straightedge, granite square or granite triangle. Dial gauges with appropriately selected resolution are used as measuring tools. The disadvantage of this type of measurement is keeping the machine out of production for a long time.

The advantage of this method is the relatively low cost of purchasing the equipment needed to perform the measurements.

• Measurements of kinematic and geometric accuracy using a telescopic kinematic bar

The measurements using a kinematic rod are based on analysing the shape of a pie chart that is performed in three parallel planes. One of the most popular systems used for this purpose is the Renishaw Ballbar QC20-W [1]. It is a wireless system consisting of a telescopic rod with magnetic ball joints on both ends (Fig. 2.). One of the joints is placed on the stationary machine table and the other in the spindle. Between them there is a telescopic rod with a precise measuring system installed inside.

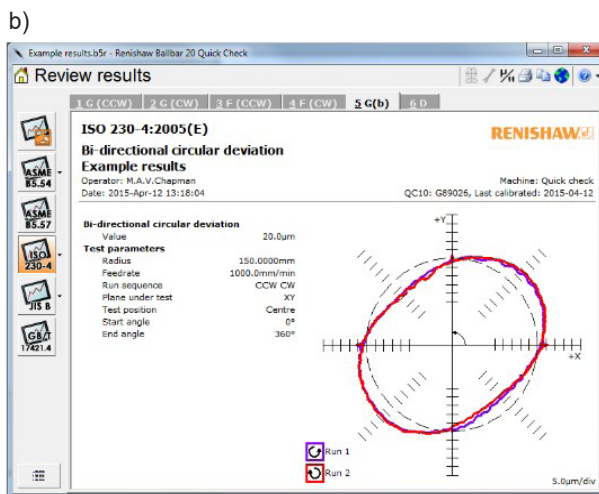

Fig. 2. Renishaw system: a) Renishaw QC20-W Ballbar b) Renishaw analysis in accordance with ISO230-4 [1]

The CNC tool machine shall be programmed to perform interpolation circular motion in parallel planes XY, XZ and YZ in the direction of CW and CCW. The collected data is sent to a PC, where Renishaw software calculates the parameters of total accuracy (circularity, circularity deviation), in accordance with such international standards as ISO230 and ANSI / ASME B5.54 or Renishaw's own analysis reports. The report uses mathematical analysis to diagnose many individual machine errors such as backlash, recurrence error, regular vibration, irregular vibration, lag error, scale error, axis perpendicular error, etc. Data is displayed in graphic or numerical format. It is possible to test the simultaneous work in five axes using a Ballbar. The test is performed similarly to the method of milling a control cone in accordance with ISO 10791-7 (NAS979), but without cutting process load. The analysis software will correctly calculate the circularity, but the machine diagnosis requires careful interpretation because the system is designed mainly for 3-axis tests [1].

The disadvantages of the Ballbar system is fact that the measurements are only carried out in a narrow space limited by bar lengths (commercial lengths vary from 50 to 600 mm). The measurement path must always be in the shape of a full circle or arc.

The advantage of the Ballbar QC20-W system is that it can be used in workshop conditions due to its resistance to dirt. The wireless transmission allows testing with

closed machine covers. Based on the measurements made, the diagnostic program is able to determine with what accuracy the element can be made at a given machining centre.

• **Measurement of positioning accuracy and geometry using a laser interferometer**

Laser interferometers are the devices most commonly used for measuring the accuracy of numerically controlled machines as well as for their calibration. An example of such a solution is a Renishaw XL-80 laser interferometer [6]. With its help, after applying the appropriate optical configuration (Fig. 3.), it is possible to perform:

- linear measurements thanks to which the positioning accuracy along the measured axis is determined, backlash etc.,
- angular measurements, enabling the determination of vertical and horizontal deviations along the concerned axis,
- straightness measurements, enabling determination of the error in vertical and horizontal planes for the movement of the considered axis,
- rotary axis measurements, which enables assessment of positioning accuracy for rotary axes,
- measurement of perpendicularity, which allows the assessment of the nominal angle deviation of two selected considered axes.

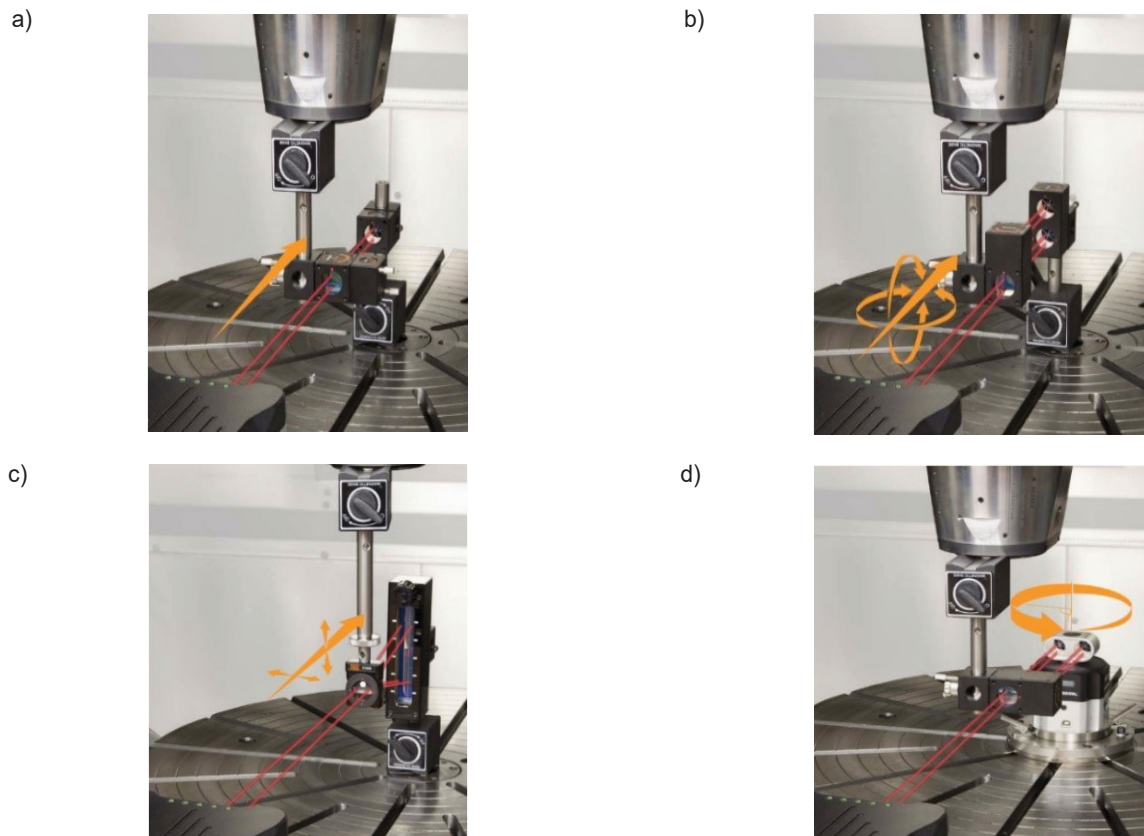

Fig. 3. Renishaw XL-80 laser interferometer in the configuration for: a) linear measurements, b) angular measurements, c) straightness measurement, d) rotary axis measurement using the XR20-W head [6]

The advantages of this measuring method are, versatility of applications, high accuracy, the possibility of using over long distances. With the use of appropriate software, it is possible to generate a measurement report in accordance with international standards (ISO 230-2).

The disadvantage is the need to take measurements with the machine's open covers, optics that require careful handling, long time out of production due to preparation and measurements of the machine tool.

Own procedures developed in flexible manufacturing systems for measuring the geometry and kinematics in automatic mode

• Rectangular master part

The first example of this realization is the use of an master part in the form of a cuboid measuring 250x250x220 mm and a hole diameter of 60 mm (Fig. 4.), installed on a movable pallet stored in an automatic fixture store. The FMS line on which the project was carried out consists of six horizontal milling centres: three five-axis machines in the TT system (tilting - rotary table), and three four-axis t-machines (rotary table). The numeric centres are equipped with Sinumerik 840D Powerline control. The entire line is managed by the central JFMX system [16].

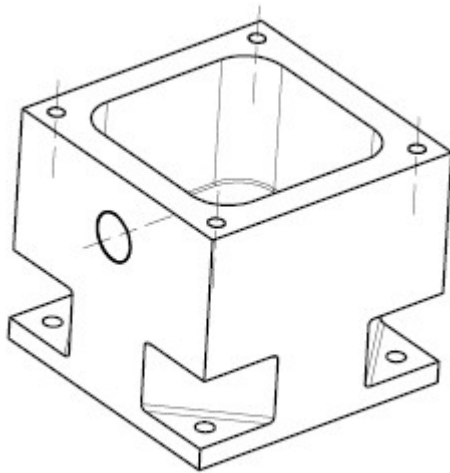

Fig. 4. Isometric view of the rectangular master part

A common problem that occurred during the operation of the machines installed on this line was related to the thermal deformation of the machine's body. That contributed to the change of their geometry, resulting in changes of machine zero position and had a significant impact on the kinematic center point during axis rotation. After every problem with the quality of structural components manufactured on the machine in question, the analysis of finished product indicated potential problems with the machine geometry. So the procedure

implemented by the manufacturer was performed to determine the geometric correctness [9, 10]. These activities took about two hours. In case that machine compensation was necessary, the time was extended to three hours. It should be noted, that not always the quality problems of the produced components were due to the geometric reasons of the machines, in such cases the previously mentioned two-hour tests were a waste of time.

To automate the machine verification process, a CNC program was created using an rectangular master part in the form of a cube, an RMP60 probe [12] and Sinumerik measuring cycles [13].

The program's task is to measure the selected characteristics of the reference master cube, which enables the assessment of parameters such as:

- correctness of the probe RMP60 calibration [12],
- correctness machine zero position in X, Y, Z axes,
- correctness of machine's geometry in the range, perpendicularity of machine axes [X,Z], [Y,Z].

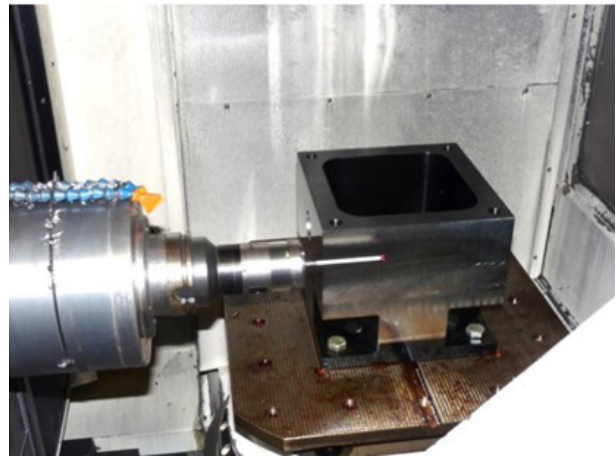

Fig. 5. View of the rectangular master part with the RMP60 object probe placed in a 4-axis horizontal machining center

The measured characteristic values are automatically saved on the disk of the central computer managing the entire production line, which allows access to information at any time.

The most important feature of the self-testing program is the function that, after completing the measurement, if necessary, when the assumed tolerance is exceeded, it blocks the production on a given machine and by using sound or light signals and appropriate M-functions calls the operator. The controller display shows information about the characteristic that has been exceeded. At the production line management stand, a prompt is displayed pointing out the machine being blocked. If the problem concerns the correctness of machine zero position, it is possible to automatically correct the machine parameters in the service mode. After re-verification of the machine's suitability for the process, if the tested parameters are

within the tolerance, the machining centre is unlocked and restored to production.

The automatic test, taking into account the automatic correction, lasts approximately 10 minutes, which gives considerable time savings, and allows significantly reducing the number of non-compliant parts produced on the FMS line in question. The improvement of the quality of manufactured parts allowed improving the assembly operations performed on the manufactured structural components (no calibration required for mating the components, etc.).

• Reference master sphere, reference master solid

As part of the research and implementation work carried out on the FMS line in the company dealing with the production of aviation components, a system was developed and implemented whose task is to plan or force to analyse the suitability of the machining centre for the process. The aforementioned line consists of three horizontal machining centres: five axis in the HT configuration (Fig. 6.), and a high storage warehouse for tooling. The whole is handled by a automatic conveyor whose task is to transport fixtures between machining centres, loading stations and fixtures magazine.

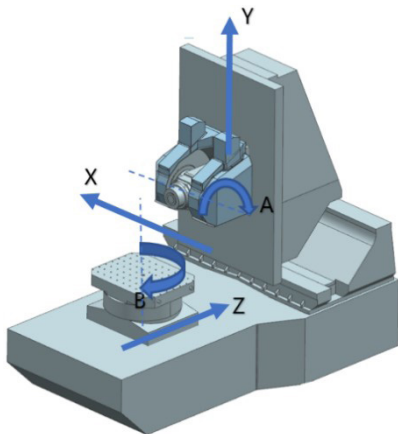

Fig. 6. Horizontal machining center with a rotary table and tilting head (HT)

Due to the variety of the manufactured elements, variability of loads during machining and relatively short series, it was necessary to constantly monitor machining centres for process suitability. For this purpose, measurement procedures were developed using the probe, master object in the form of a cuboid with the characteristic dimensions of 750x750 mm, and two reference spheres placed on the machining pallet (Fig. 7). The measurement procedure was divided into several stages. The individual stages were designed to reflect, as far as possible, the acceptance instructions contained in the standards [4, 9], and the acceptance documentation of the machine manufacturer [2].

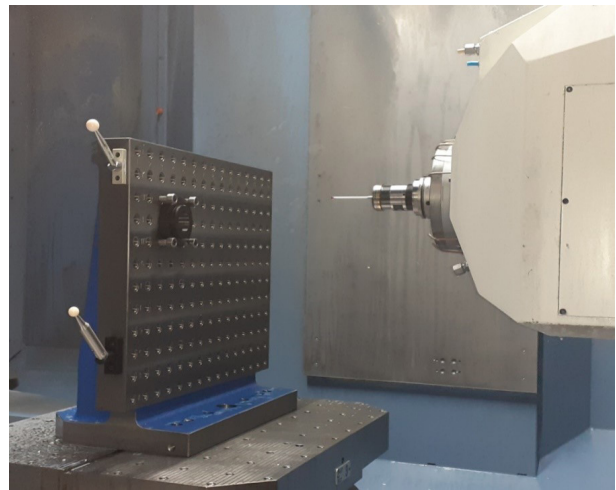

Fig. 7. View of the calibration master (two reference sphere's, calibration column), together with the RMP60 probe, inside 5-axis machine center

First, the cuboid temperature is measured to compensate for the nominal geometrical values of the artefact. The temperature is measured by probe TP44.10 [3].

The next stage is the analysis of the geometrical properties of the machining centre using the RMP60 object probe [12] and measuring cycles [14]. Straightness measurements of individual linear axes are made in the YZ, ZX, XY planes. The angular relationships between the YX, YZ and XZ axes are also checked.

The next step is to assess the correctness of the machine zero position, and to check the error of parallelism of the rotation axis of the table B in relation to the Y axis in the ZY and XY planes. The assessment of these parameters is made by measuring the position of two artefacts in the form of reference balls whose position in space is changed by means of the rotation axis B in three characteristic positions (B0, B-90, B-180).

The acceptable deviations were adopted in accordance with the acceptance requirements contained in the purchase contract of the analysed machining center [2, 9, 10].

In case of positive result of the above measurements, the correctness of geometric vectors is tested; they are used to define 5-axis transformations (TRAORI, TCARR) [15]. The measurement takes place in such a way that with the help of the object probe three positions of the measuring ball are read for each of the two rotary axes (A, B) [14]. The results obtained in this way are compared with the current settings.

Similarly to the described example from subchapter Rectangular master part, reports are generated and if necessary, production is blocked on the tested machine centre. If the tolerance for machine zero position or the permissible deviations for kinematic vectors is exceeded, it is possible to automatically calibrate the above parameters in the service mode. Auto calibration is

possible only when the geometrical criteria (straightness, perpendicularity) are met.

Conclusions

The technology of assembly operations in aviation industry is closely related to the accuracy of machining parts. In the case of assembly with incomplete interchangeability of parts, one can afford lower accuracy. This lower accuracy can be corrected by assembly methods using compensators or selection. However, there are parts where full interchangeability is required and assembly accuracy is decisive. These types of parts are produced on CNC milling machines implemented in the FMS lines discussed in this article. In such cases, the accuracy of machining determines not only the usefulness of the part but also the costs of the production.

The practical application of the solutions presented in the article (chapter: Own procedures developed in flexible manufacturing systems for measuring the geometry and kinematics in automatic mode), has significantly improved the accuracy of the parts, which eliminated a number of deficiencies or the need for re-corrective machining to ensure proper assembly of the assemblies and functioning of the product. The introduced control on expensive aviation parts significantly reduced costs and processing time.

References

- [1] Ballbar testing in tandem with circle, diamond, square machining tests. Technical white paper: Rev 1m TE336. Available on-line: resources.renishaw.com [access: 10.05.2019].
- [2] Geometric test report: 1.1362.18E 23 MCM s.p.a 23 October 2018 .
- [3] Hexagon Manufacturing Intelligence. Part of Hexagon - m&h Radio-Wave Touch Probe V01.00-REV01.00. Release date: 2016-01-15.
- [4] ISO 10791-1: 2015 - Test conditions for machining centres - Part 1 - Geometric tests for machines with horizontal spindle and with accessory heads (horizontal Z-axis).
- [5] Józwiak Jerzy. 2018. Experimental methods of error identification in CNC machine tool operation. Lublin: Lublin University of Technology.
- [6] Laserowy system pomiarowy XL-80. Available on-line: resources.renishaw.com [access: 03.03.2020].
- [7] Majda Paweł. 2011. „Pomiary i kompensacja błędów geometrycznych obrabiarek CNC”. *Inżynieria Maszyn* 16(1-2): 126-134.
- [8] Mutilba Unai, Gomez-Acedo Eneko, Kortaberria Gorka, Olarra Aitor, Yagüe-Fabra Jose A. 2017. Traceability of On-Machine Tool Measurement: A Review. *Sensors* 17(7): 1605.
- [9] PN-ISO 230-1: 1998 - Przepisy badania obrabiarek. Dokładność geometryczna obrabiarek pracujących bez obciążenia lub w warunkach obróbki wykańczającej.
- [10] PN-ISO 230-2: 1999 - Przepisy badania obrabiarek. Wyznaczenie dokładności i powtarzalności pozycjonowania osi sterowanych numerycznie.
- [11] Rahman M., Heikkala J., Lappalainen K. 2000. „Modeling, measurement and error compensation of multi-axis machine tools. Part I: Theory”. *International Journal of Machine Tools & Manufacture* 40(10):1535-1546.
- [12] RMP60 radio transmission probe. Available on-line: resources.renishaw.com [access: 12.05.2019].
- [13] Siemens. 2001. SINUMERIK 840D/810Di/810D – Cykle pomiarowe. Podręcznik użytkownika.
- [14] Siemens. 2015. SINUMERIK 840d SI/828d - Cykle pomiarowe. Podręcznik programowania.
- [15] Siemens. 2011. SINUMERIK 840d SI/828d - Przygotowanie do pracy. Podręcznik programowania.
- [16] <https://www.mcmspa.it/management-software> [access: 10.01.2020].

mgr inż. Damian Basara
Politechnika Rzeszowska im. I. Łukasiewicza,
Wydział Budowy Maszyn i Lotnictwa
al. Powstańców Warszawy 8, skr. pocztowa 85,
35-959 Rzeszów, Polska
e-mail: damian.basara@gmail.com

dr hab. inż. Leszek Skoczylas
Politechnika Rzeszowska im. I. Łukasiewicza,
Wydział Budowy Maszyn i Lotnictwa
al. Powstańców Warszawy 8, skr. pocztowa 85,
35-959 Rzeszów, Polska
e-mail: lsktmiop@prz.edu.pl



A może nad morze

KRYNICA MORSKA

Zapraszamy od czerwca
Zaplanuj swój urlop już dziś
do Naszego ośrodka w **KRYNICY MORSKIEJ**
www.dpt-krynica-morska.pl rezerwacja@dpt-krynica-morska.pl

ANALYSIS OF THE IMPACT OF SURFACE ROUGHNESS ON THE CAPACITY OF ADHESIVE JOINTS FROM ALUMINUM ALLOY 2024

Analiza wpływu chropowatości powierzchni na nośność połączeń klejowych stopu aluminium 2024

Łukasz BĄK

Ewelina GUŻLA

Michał ŁYKO

ORCID 0000-0002-7359-6007

DOI: 10.15199/160.2020.2.5

Abstract: The purpose of the article was to deepen the state of knowledge regarding the impact of surface roughness on the capacity of single-lap adhesive joints from aluminum alloy 2024. The surfaces with a triangular outline and various height and longitudinal parameters have been deliberately shaped. The surface roughness of the samples was shaped by milling with four different table feed of 30, 50, 70 and 90 [mm/min]. Surface roughness was tested in a 2D system using a contact profilometer. The samples were connected using Loctite EA 3430 epoxy adhesive and then subjected to a static tensile test. As a result of the performed statistical analysis, it was shown that in the adopted variability area, along with the increase of the feed value, the value of roughness parameters and the capacity of joints increased. The highest capacity was obtained for the parameters $R_a = 20,83 \mu\text{m}$, $R_z = 101,33 \mu\text{m}$, $R_v = 41,97 \mu\text{m}$, $R_{ku} = 2,62 \mu\text{m}$, $R_{Sm} = 0,746 \text{ mm}$.

Keywords: surface roughness, lap adhesive joints, static tensile test

Streszczenie: Celem artykułu było pogłębienie stanu wiedzy dotyczącej wpływu chropowatości powierzchni na nośność jednozakładkowych połączeń klejowych stopu aluminium 2024. W sposób celowy ukonstruowano powierzchnie o zarysie trójkątnym, różniące się wysokościowymi i wzdłużnymi parametrami chropowatości. Chropowatość powierzchni próbek kształtowano poprzez frezowanie z czterema różnymi prędkościami posuwu wynoszącymi 30, 50, 70 i 90 [mm/min]. Chropowatość powierzchni zbadano w układzie 2D przy pomocy profilometru stykowego. Próbki sklejono z wykorzystaniem kleju epoksydowego Loctite EA 3430, a następnie poddano statycznej próbie rozciągania. W wyniku przeprowadzonej analizy statystycznej wykazano, że w przyjętym obszarze zmienności wraz ze zwiększaniem wartości posuwu zwiększała się wartość parametrów chropowatości oraz nośność połączeń. Najwyższą nośność uzyskano dla parametrów $R_a = 20,83 \mu\text{m}$, $R_z = 101,33 \mu\text{m}$, $R_v = 41,97 \mu\text{m}$, $R_{ku} = 2,62 \mu\text{m}$, $R_{Sm} = 0,746 \text{ mm}$.

Słowa kluczowe: chropowatość powierzchni, zakładkowe połączenia klejowe, statyczna próba rozciągania

Introduction

The phenomenon of adhesion is one of the factors conditioning the formation of adhesive joints. There are several theories that describe this phenomenon. One of them is mechanical theory of adhesion. According to this theory, due to the penetration of glue into the irregularities on the adhered surface, it is possible to create some kind of mechanical anchors between the surface and the glue. These anchors are capable of carrying significant loads. The topography of the surface determines the value of mechanical adhesion. Therefore, surface roughness can affect adhesive properties and, as a result, strength properties of the adhesive joint [4, 5].

There are several methods that allow modifying the geometric structure of the surface. One of them is mechanical treatment. The most commonly used methods of mechanical surface pre-treatment include: shot blasting, shot peening, grinding and abrasive blasting [7].

A lot of research has been carried out regarding the impact of various machining methods on the geometric structure of the surface and the capacity of the joints. For example, in paper [8] the author compared the effects of superfinishing, grinding and lapping on surface roughness and adhesive joint strength of steel. According to this paper, the highest values of joint strength were obtained for lapping, although the height parameters for these surfaces were relatively low.

In paper [6] the influence of sandblasting on surface properties for adhesion was examined. The research has shown that surface roughness and its adhesive properties depend more on the type of abrasive material than the applied pressure.

The objective of work [13] was to investigate the effect of sandblasting and laser texturing on the roughness parameters and joint strength from 30CrMnSiA steel. The analyzes presented in the work showed that, as a result of sandblasting and laser texturing, roughness

parameters such as Rz increased to 2,85 μm and 4,19 μm from 0,75 μm and Ra increased to 0,39 μm and 0,63 μm from 0,22 μm . Furthermore, the strength of the adhesive bond increased by 151% to 465.9% respectively after sandblasting and laser texturing.

The author of the work [10] pointed out that the shear strength of adhesive joints that were damaged as a result of breaking adhesive bonds should be associated with the roughness parameters such as I_r , Δa and Δq . On the other hand, the strength of the connections in which cohesive bonds were broken depended (to a small extent) on the height parameters R_y , R_m , R_z and R_a .

The subject of the work [12] was to examine the influence of 3D geometric structure on the strength of adhesive joints. The work proved that the hybrid parameters such as S_{sc} , S_{dr} , S_{dq} can be used to control the correctness of surface preparation and forecast shear strength of lap adhesive joints glued with elastic adhesive compositions that are subjected to adhesive or adhesive-cohesive damage.

However, modifying the adhered surface roughness (by mechanical treatment, for example), does not always guarantee an increase in the strength of the connection. Excessive surface roughness and a large number of narrow pores may hinder the penetration of adhesive into the unevenness and, as a result, weaken the connection. In such cases it is very important to apply the right pressure during gluing [3, 5]. What is more, some research points out that in some cases mechanical surface pre-treatment may weaken the adhesive joint by

forming excessive compressive stresses or structural micro-damage [1, 4, 11].

Therefore, it is reasonable to conduct further research on the impact of surface roughness on the capacity of adhesive joints and to search for surface treatment methods that guarantee the largest increase in joint strength.

Material and methods

The purpose of the work was to deepen the state of knowledge regarding the impact of surface roughness on the capacity of single-lap adhesive joint from aluminum alloy 2024. The chemical composition of this alloy is shown in table 1.

2024 aluminum alloy is characterized by a high strength and high temperature resistance. Its disadvantages include poor weldability and low corrosion resistance. It is mainly used in the automotive, aviation, machine and defense industries [2, 9].

The first stage of the study was to prepare the surface of the samples for adhesive bonding. The surfaces with a triangular outline and various height and longitudinal parameters have been deliberately shaped. For this purpose, the samples were milled using Jafo FWF 32J2 machine. The milling process was carried out at a constant spindle speed n . In order to obtain various values of surface roughness parameters, different values of table feed v_f were used (Table 2.).

Table 1. The chemical composition of aluminum alloy 2024 [2]

Component, weight %											
Si	Fe	Cu	Mn	Mg	Cr	Ni	Zn	Ti	V	Others*	Al
max 0,50	max 0,50	3,8 - 4,9	0,30 - 0,90	1,2 - 1,8	max 0,10	-	max 0,25	max 0,15	-	max 0,05	remaining
*Others, total \leq 0,15%											

Table 2. Milling parameters [own elaboration]

Variant	Spindle speed n [r/min]	Table feed v_f [mm/min]
1	140	30
2		50
3		70
4		90

Then, roughness measurements of the treated surface were carried out. The contact stylus profilometer Taylor Hobson Surtronic 25 and TalyProfile Lite software were used for the tests. The evaluation length was 12,5 mm.

The next step was to make a single-lap adhesive joint using Loctite EA 3430 adhesive. Loctite EA 3430 is a general purpose, two-component epoxy adhesive. It is characterized by a high rate of cure at room temperature. It has good gap filling properties. It is suitable for rough and poorly adherent surfaces [14]. The dimensions of the connection were 12.5 x 25 mm.

The final stage was to subject the joints to a static tensile test on a Zwick Roell Z030 testing machine. The test speed was 5 mm/min and the initial force was 30 N.

Results

The selected surface profilographs, showing the differences in the geometric surface for different values of table feed v_f , are placed below (Fig. 1).

The milling process was carried out at a constant spindle speed of 140 r/min. The table feed was changed in the range from 30 to 90 mm/min. Based on the

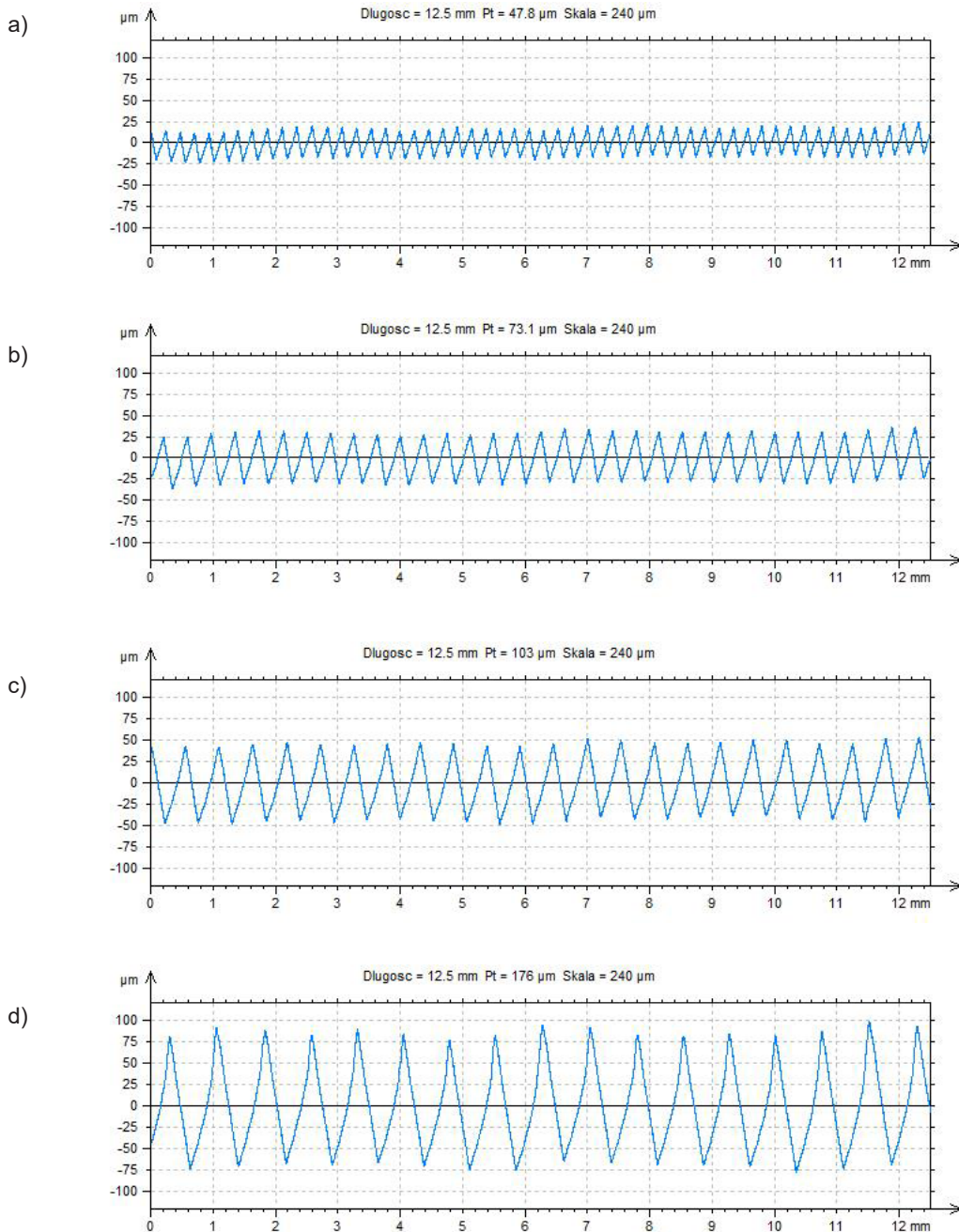

Fig. 1. Surface profilographs: a) table feed 30 mm/min, b) table feed 50 mm/min, c) table feed 50 mm/min, d) table feed 90 mm/min [own elaboration]

Table 3. The average values of the selected roughness parameters and the capacity [own elaboration]

No.	v_f [mm/min]	R_a [μm]	R_z [μm]	R_v [μm]	R_{sk} [μm]	R_{ku} [μm]	R_{Sm} [mm]	capacity P [N]	standard deviation of capacity [N]
1	30	8,87	35,83	17,17	0,100	1,87	0,231	1403	259
2	50	15,87	58,40	28,30	0,09	1,80	0,377	2167	208
3	70	17,93	75,90	36,23	0,13	1,95	0,536	1836	201
4	90	20,83	101,33	41,97	0,63	2,62	0,746	2642	496

profilographs showed above, it can be seen that as the table feed increased, the surface roughness of the samples increased.

The table above presents the average values of selected roughness parameters and capacity of connections (Table 3.)

The highest capacity of the adhesive connection was obtained for samples whose surface was treated at a table feed of 90 mm/min, whereas the lowest capacity was obtained for samples milled with a table feed of 30

mm/min. Based on table 3, it can be concluded that as the table feed increased, the surface roughness increased. However, this did not quite translate into increasing the load capacity of the connection, as evidenced by variant 3. The highest standard deviation value was observed for variant 4. This variant is therefore characterized by the greatest variability.

The test results were subjected to statistical analysis. In the first step of the analysis, box plots were created. Selected box plots are presented in figure 2.

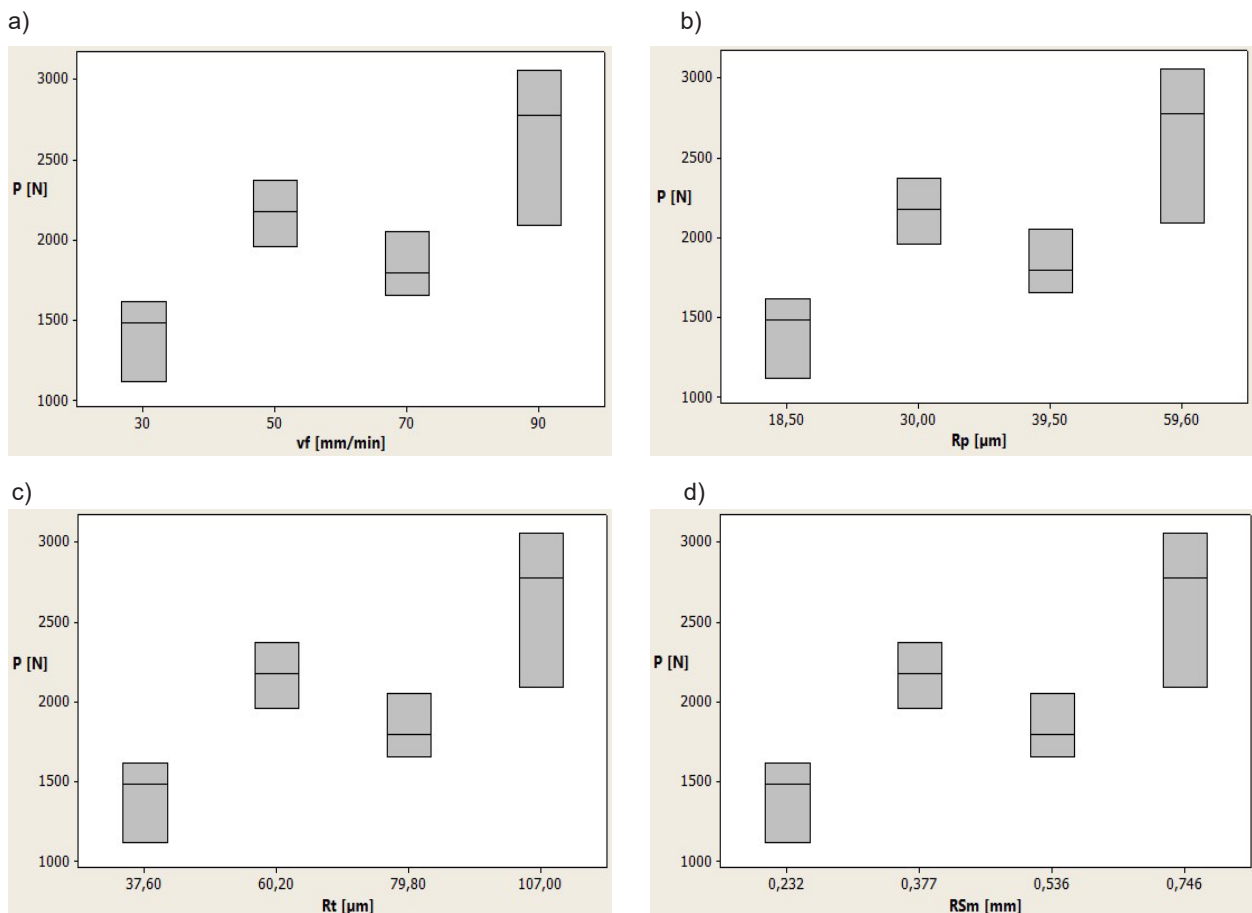

Fig. 2. Box plots: a) dependence of P on v_f , b) dependence of P on R_p , c) dependence of P on R_t , d) dependence of P on R_{Sm} [own elaboration]

Based on the graphs, it can be concluded that the largest spread of capacity values was obtained for the fourth variant. Moreover, in most cases the data distribution is asymmetrical.

The next stage of statistical analysis was the one-way analysis of variance (ANOVA) which allowed studying the

influence of the input variables (table feed and roughness parameters) on the output variable (capacity of the connection). Statistical significance $\alpha=0.05$ was adopted. The results of the ANOVA and regression equation analysis are shown in table 4.

Table 4. Results of the one-way analysis of variance (ANOVA), regression equation analysis and Pearson's correlation coefficients [own elaboration]

Parameter	Independent variable	Pv1	Correlation coefficient	Pv2	Regression equation
P	v_f	0,008	0,726	0,007	$y_p=995,8+16,94x_{v_f}$
P	Rp	0,008	0,761	0,004	$y_p=1035+26,40x_{R_p}$
P	Rv	0,008	0,726	0,007	$y_p=753,5+40,70x_{R_v}$
P	Rz	0,008	0,756	0,004	$y_p=896,5+16,44x_{R_z}$
P	Rc	0,008	0,757	0,004	$y_p=925,8+16,07x_{R_c}$
P	Rt	0,008	0,752	0,005	$y_p=920,8+15,34x_{R_t}$
P	Ra	0,008	0,757	0,004	$y_p=610,0+88,30x_{R_a}$
P	Rq	0,008	0,755	0,005	$y_p=731,2+68,70x_{R_q}$
P	Rsk	0,008	0,666	0,018	$y_p=1649+1527x_{R_{sk}}$
P	Rku	0,008	0,638	0,025	$y_p=-70,3+1012x_{R_{ku}}$
P	RSm	0,008	0,732	0,007	$y_p=1069+1994x_{R_{sm}}$

P – capacity, Pv1 – probability level in the one-way analysis of variance (ANOVA), Pv2 – probability level in the analysis of the linear correlation coefficient

Based on the Pv1 value, it can be stated that in the adopted area of input parameter variability, values of table feed and selected roughness parameters have a significant impact on the capacity of the samples. What is more, Pearson's correlation coefficients indicate quite strong positive linear correlations between capacity and roughness parameters or table feed. The strongest linear correlations occur between strength and Rc, Rz and Rq parameters. This is confirmed by Pv2 values, which are

lower than 5% for all independent variables. Based on regression equations, which are a kind of mathematical model of the phenomenon, it can be stated that in the adopted area of variability, increasing the table feed and thus increasing the roughness parameters of the glued surface, contributes to increasing the capacity of the tested adhesive joints. The results of the regression equation analysis for the selected roughness parameters are presented below (Fig. 3.).

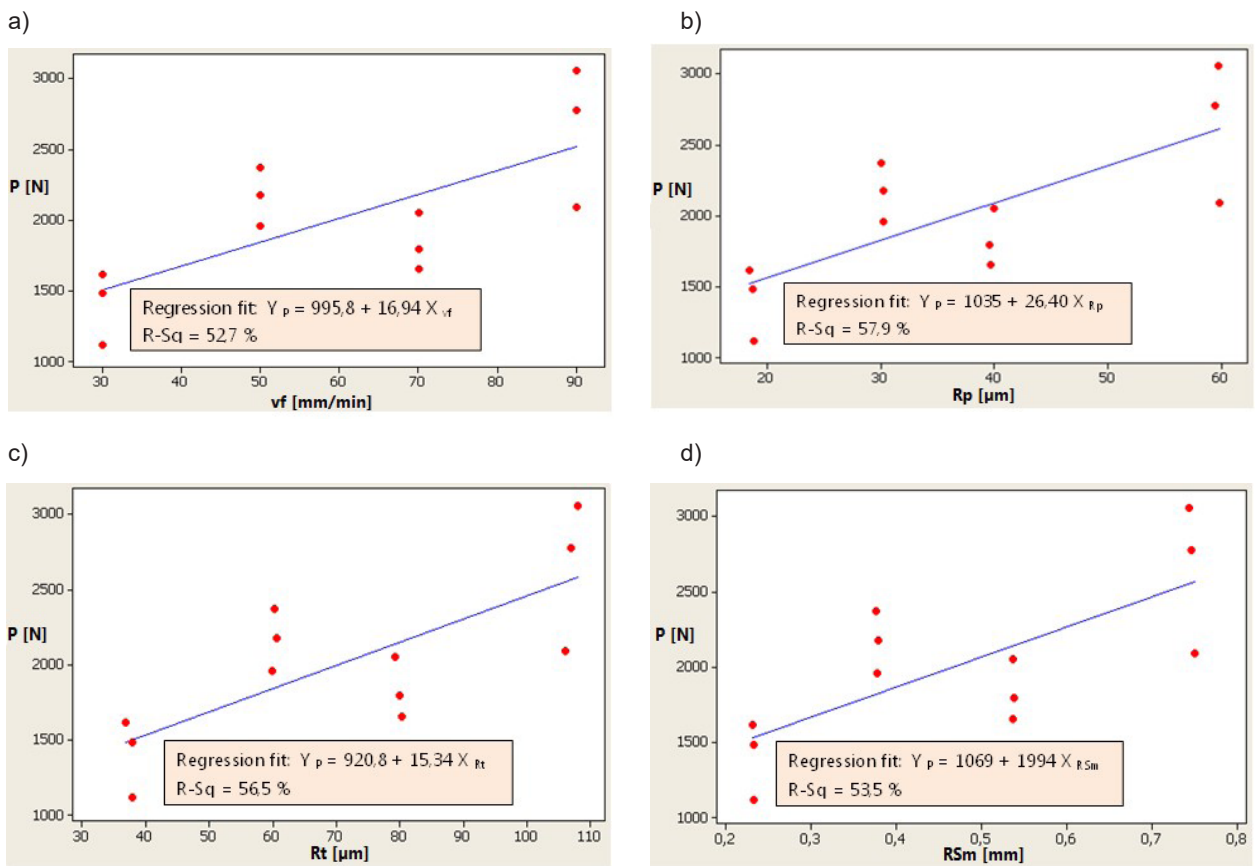

Fig. 3. Graphs and regression equations: a) dependence of P on v_f , b) dependence of P on R_p , c) dependence of P on R_t , d) dependence of P on R_{Sm} [own elaboration]

The last step of the analysis was conducting Student's t-test, in which the average capacity values for four different surface treatment variants were compared (Table 5).

The results of the Student's t-test prove that the use of different table feed and thus achieving different values

of roughness parameters causes a significant difference between the capacity of most compared samples (in the adopted variation area). This difference is most evident in the samples milled at a table feed of 30 mm/min and 50 mm/min.

Table 5. Student's t-test results

Pv [%]	$v_f = 30$ mm/min	$v_f = 50$ mm/min	$v_f = 70$ mm/min	$v_f = 90$ mm/min
$v_f = 30$ mm/min	-			
$v_f = 50$ mm/min	0,890	-		
$v_f = 70$ mm/min	4,407	5,931	-	
$v_f = 90$ mm/min	1,552	11,684	4,548	-

Conclusions

The use of machining treatment such as milling enables a deliberate constitution of surface roughness. Based on the analysis of the impact of selected roughness parameters on the capacity of 2024 aluminum alloy adhesive joints, it can be concluded that in the adopted area of input parameters variability, increasing table feed contributes to increasing the surface roughness, which in turn translates into increased joint load capacity.

The statistical analysis shows that the values of the considered roughness parameters significantly affect the capacity of the connections. Furthermore, the analysis of regression equations and linear correlation coefficients indicates a fairly strong linear correlation between the capacity and roughness parameters of the samples.

References

- [1] da Silva L.F.M., das Neves P.J.C., Adams R.D., Wang A., Spelt J.K. 2009. "Analytical models of adhesively bonded joints Part II: Comparative study". International Journal of Adhesion and Adhesives 29: 331-341.
- [2] Dobrzański L. (red.). 2010. Leksykon Materiałoznawstwa. Praktyczne zestawienie norm polskich, zagranicznych i międzynarodowych. Cz. 4, rozdział 1: Metale nieżelazne i ich stopy. Warszawa: Wydawnictwo Verlag Dashofer.
- [3] Godzimirski J. 1994. „Czynniki kształtujące wytrzymałość połączeń klejowych”. Technologia i Automatykacja Montażu 4: 61-64.
- [4] Godzimirski J., Kozakiewicz J., Łunarski J., Zielecki W. 1997. Konstrukcyjne połączenia klejowe elementów metalowych w budowie maszyn. Rzeszów: Oficyna Wydawnicza Politechniki Rzeszowskiej.
- [5] Kuczmaszewski J. 2006. „Fundamentals of metal-metal adhesive joint design”. Lublin: Politechnika Lubelska, Oddział PAN w Lublinie.
- [6] Rudawska A., Danczak I., Müller M., Valasek P. 2016. „The effect of sandblasting on surface properties for adhesion”. International Journal of Adhesion & Adhesives 70: 176–190.
- [7] Rudawska A. 2013. Wybrane zagadnienia konstituowania połączeń adhezyjnych jednorodnych i hybrydowych. Lublin: Politechnika Lubelska.
- [8] Rudawska A. 2014. „Selected aspects of the effect of mechanical treatment on surface roughness and adhesive joint strength of steel sheets”. International Journal of Adhesion & Adhesives 50: 235–243.
- [9] Sieniawski J. 2009. „Stopy aluminium stosowane w technice lotniczej”. Mechanik 7: 649-654.
- [10] Zielecki W. 2007. „Wpływ rozwinięcia struktury powierzchni na wytrzymałość zakładkowych połączeń klejowych”. Technologia i Automatykacja Montażu 1,2: 108-111.
- [11] Zielecki W., Pawlus P., Perłowski R., Dzierwa A. 2013. “Surface topography effect on strength of lap adhesive joints after mechanical pre-treatment”. Archives of Civil and Mechanical Engineering 13: 175-185.
- [12] Zielecki W., Pawlus P., Perłowski R., Dzierwa A. 2011. „Analiza wpływu struktury geometrycznej powierzchni w układzie 3D na wytrzymałość połączeń klejowych”. Technologia i Automatykacja Montażu 1: 33-36.
- [13] Ziwei Feng, Hongyun Zhao, Caiwang Tan, Jun Chen, Yong Wang, Bo Chen and Xiaoguo Song. 2019. “Modification of surface treatment on the strength of 30CrMnSiA steel adhesively bonded joints”. Materials Research Express 6: 116521.
- [14] https://www.woronko-kleje.pl/sg_obrazki_/00029403_zalac_001.pdf [access: 10.05.2019].

dr inż. Łukasz Bąk
Wydział Budowy Maszyn i Lotnictwa, Katedra Przeróbki
Plastycznej
al. Powstańców Warszawy 8, 35-959 Rzeszów, Polska
e-mail: lbak@prz.edu.pl

mgr inż. Ewelina Guźla
Wydział Budowy Maszyn i Lotnictwa, Katedra Technologii
Maszyn i Inżynierii Produkcji
al. Powstańców Warszawy 8, 35-959 Rzeszów, Polska
e-mail: e.guzla@prz.edu.pl

mgr inż. Michał Łyko
Wydział Budowy Maszyn i Lotnictwa, Katedra Technologii
Maszyn i Inżynierii Produkcji
al. Powstańców Warszawy 8, 35-959 Rzeszów, Polska

korozja kosztuje! *

*) straty korozyjne szacuje się na 3-6% PKB



na życzenie wysyłamy bezpłatny
egzemplarz okazowy:
redakcja@ochronaprzedkorozja.pl

Forum wymiany wiedzy
i doświadczeń na temat
ochrony materiałów
przed skutkami korozji

www.ochronaprzedkorozja.pl
www.sigma-not.pl

COMPARATIVE ANALYSIS OF WETTING ABILITY OF ALUMINUM SHEETS WITH DIFFERENT SURFACE ROUGHNESS PARAMETERS BY EPOXY ADHESIVE

Analiza porównawcza zdolności zwilżania przez klej epoksydowy blach aluminiowych o różnych parametrach chropowatości powierzchni

Jacek DOMIŃCZUK ORCID 0000-0003-2536-3440
Anna KRAWCZUK ORCID 0000-0001-6227-7740

DOI: 10.15199/160.2020.2.6

Abstract: The article presents the analysis of the wetting ability by Epidian 5 epoxy resin with hardener Z1 of EN AW-2017A aluminum alloy sheets. The material sheets were subjected to the selected methods of processing in order to obtain different parameters of the geometric development of the surface. The energy state of the surface layer was examined on the prepared surfaces, taking the polar and non-polar free surface energy components into account. On the basis of the obtained results, wetting envelopes were determined, which represent the limit value of the surface energy components of the wetting liquid, ensuring good wetting. As part of the research, an analysis of the possibilities of achieving maximum adhesion work between a solid and a liquid in the event of changes in the contact angle was also conducted. This analysis allows one to determine how the parameters of the test adhesive deviate from the ideal, i.e. those for which the surface tension at the interface reaches the minimum value. Based on the results of the analysis, a summary was prepared, showing the ability of the adhesive to wet surfaces with different roughness parameters.

Keywords: free surface energy, contact angle, aluminum alloy, epoxy adhesives

Streszczenie: W artykule przedstawiono analizę zdolności zwilżania przez klej Epidian 5 z utwardzaczem Z1 powierzchni blach ze stopu aluminium EN AW-2017A. Blachy poddano wybranym sposobom obróbki w celu uzyskania odmiennych parametrów rozwinięcia geometrycznego powierzchni. Na tak przygotowanych powierzchniach przeprowadzono badania stanu energetycznego warstwy wierzchniej z uwzględnieniem składowej polarnej i niepolarniej swobodnej energii powierzchniowej. Na podstawie otrzymanych wyników wyznaczono krzywe zwilżania, które przedstawiają graniczną wartość składowych swobodnej energii powierzchniowej cieczy zwilżającej, zapewniające uzyskanie dobrego zwilżania. W ramach badań przeprowadzono również analizę możliwości osiągnięcia maksymalnej pracy adhezji między ciałem stałym, a cieczą w przypadku zmian kąta zwilżania. Analiza ta pozwoliła na określenie na ile parametry badanego kleju odbiegają od idealnych, czyli takich, dla których napięcie powierzchniowe na granicy faz osiąga wartość minimalną. W oparciu o uzyskane wyniki analiz dokonano zestawienia obrazującego zdolność kleju do zwilżania powierzchni o różnych parametrach chropowatości.

Słowa kluczowe: swobodna energia powierzchniowa, kąt zwilżania, stop aluminium, kleje epoksydowe

Introduction

Adhesive technology, due to a number of its advantages, is of a great importance in industrial production. In particular, it has found applications in the aerospace, automotive or maritime industries to connect aluminum structures. Bonding offers the possibility of joining elements with large surfaces made of various materials that may vary in thickness. The structures produced using the mentioned technology are characterized by a lower weight and lack of thermal deformation or residual stresses that arise due to heating [8, 14, 15].

As research shows, one of the important factors affecting the creation of adhesive joints is to achieve a strong adhesive bond [3, 4, 10, 12]. This is possible through the selection of a suitable adhesive, which would be characterized by a lower value of surface

free energy than the material that we want to connect. It is also important to maintain a balance between the polar and dispersion components of the surface free energy of adhesive and the joined elements. Knowledge of the energy properties of the surface of the material and the applied adhesive composition makes it possible to conduct a wettability analysis that helps to assess the accuracy of the selection of the adhesive or the application of a specific method for preparing the surface of the material. Analysis using wetting envelopes can be an effective, simple, safe and economical tool for assessing the strength of an adhesive joint in the aspect of optimizing adhesive properties [5, 6, 11].

Aluminum alloy surface is normally covered with a naturally formed oxide layer on the surface and adsorbed impurities which must be removed to provide a strong adhesive bond. For this purpose, various mechanical, chemical or electrochemical methods of

surface treatment are used. These methods not only ensure sufficient surfacing in the geometrical sense by shaping favorable horizontal parameters from the point of view of gluing technology but also change the energy properties of the surface layer of the material. Chemical methods involving digestion in acidic or alkaline baths or the application of adhesive agents in the form of e.g. silicone compounds are not environmentally friendly. Therefore, they require the use of complicated process installations and appropriate procedures for dealing with consumed chemical compounds. All this means that simple, safe and effective methods of improving the quality of adhesive joints are sought after [1, 2, 7, 9, 10, 13, 16].

The aim of the study is to determine whether knowledge of wetting envelopes, representing the limit values of the components of surface free energy of the liquid ensures a good wetting, can be helpful in the design of adhesive joints.

Methodology

The wetting ability analysis of adhesive Epidian 5 with Z1 hardener was performed for EN AW 2017A aluminum alloy sheets subjected to selected machining methods to obtain different surface geometrical parameters.

Samples with dimensions of 25 x 100 mm and a thickness of 2 mm were prepared according to the variants presented in Table 1.

Tab. 1. Variants for the preparation of EN AW-2017A aluminum alloy samples

Variant	Method of treatment
A	Untreated
B	Treatment with non-woven fabric with a grain size of 80
C	Treatment with non-woven fabric with a grain size of 180
D	Treatment with non-woven fabric with a grain size of 320

For this purpose, disks of abrasive material of different grain size were used (Table 1). Each sample was processed according to the scheme presented in Fig. 1. Three alternating tool transitions to the workpiece were carried out.

After the treatment, the samples were cleaned in two stages with a Loctite 7061 degreasing agent. The first stage consisted of washing the samples twice with a degreasing agent and wiping them with a paper towel. In the second stage, after cleaning the samples, the degreasing agent was allowed to evaporate.

The HOMMEL TESTER T1000 contact profilometer was used to measure 2D surface roughness parameters.

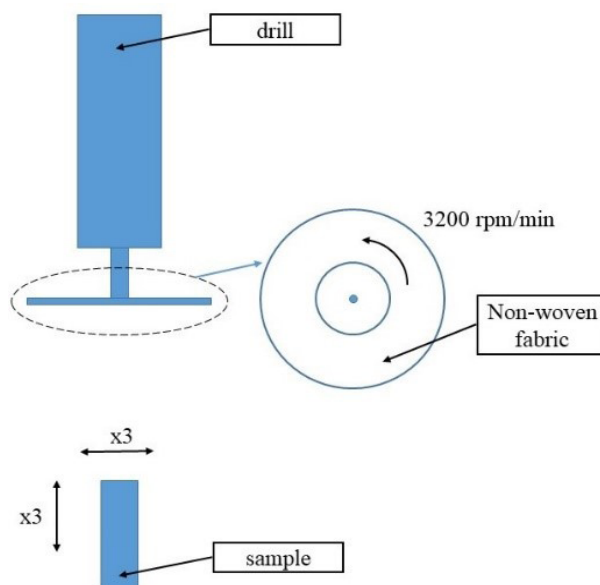

Fig 1. Diagram of processing of EN AW-2017A aluminum alloy samples

The length of the elementary section was selected in accordance with the recommendations of PN-EN ISO 4288: 2011 and equaled 0.8 mm. Measurement of surface roughness parameters was repeated five times for all variants of the treatment.

Surface-free energy and its components, for the treated samples of EN AW-2017A aluminum alloy, were determined using the Owens-Wendt method [17]. On the surface of EN AW-2017A aluminum alloy samples treated with non-woven fabric with different grain size (Table 1), droplets of measuring liquids: distilled water and diodomethane, with a volume of 4 μl , were dosed. The tests were repeated twenty times for each treatment variant. Distilled water is a strongly polar liquid and its value of polar component SEP γ_w^p is 51 mJ/m^2 with the total value of SEP γ_w equal to 72,8 mJ/m^2 . Diodomethane, on the other hand, has a polar component of 2.3 mJ/m^2 and a dispersion component of 48.5 mJ/m^2 .

On the basis of the surface tension measurements, the components of surface free energy of Epidian 5 resin with hardener Z1 were determined by the hanging drop method. Using a syringe, 20 μl droplets of epoxy adhesive were dispensed and 20 surface tension measurements were carried out. Then, with an NICHIRYO Le-20 automatic pipette, $5 \pm 0.02 \mu\text{l}$ epoxy adhesive drops were placed on the surface of the DC0 steel (the total surface free energy of the value 30,3 mJ/m^2 , non-polar component – 28,3 mJ/m^2) and 20 wetting angle measurements were taken. The measurements were carried out at $21^\circ\text{C} \pm 1$. The components of the surface-free energy of the adhesive were determined on the basis of the intersection of the wetting envelope determined on the basis of the contact angle measurements with DC01 steel with a straight line representing the value of the surface tension of the adhesive [6].

Surface tension and contact angles measurements that were used for the calculations were performed on the KRÜSS DSA30 goniometer using an automatic module for obtaining and analyzing the results.

Experimental results

Table 2 presents the average values of measurements of surface roughness parameters of the EN AW-2017A aluminum alloy subjected to the selected methods of surface preparation. The following parameters were registered: Ra parameter - arithmetic mean deviation of the roughness profile and Rz parameter- the maximum height of the profile

Based on the obtained results, it was found that subjecting the samples of the EN AW-2017A aluminum alloy with non-woven fabric with different grain size contributes to the increase of recorded roughness parameters in comparison to the untreated samples. The greatest increase in surface roughness was observed for samples treated with non-woven fabric with a grain size of 80.

The average values of contact angle measurements and components of surface-free energy together with the total value calculated using the Owens-Wendt method for EN AW-2017A aluminum alloy subjected to the selected surface preparation methods are presented in Table 3 and Figure 2.

Tab. 2. The selected 2D surface roughness parameters of EN AW-2017A aluminum alloy samples subjected to the selected surface preparation methods

	Variant ¹⁾	Ra [μm]	Rz [μm]
A	Average value	0,11	0,52
B	Average value	0,59	5,78
C	Average value	0,40	2,79
D	Average value	0,41	3,02

¹⁾ variant of surface preparation method according to Table 1

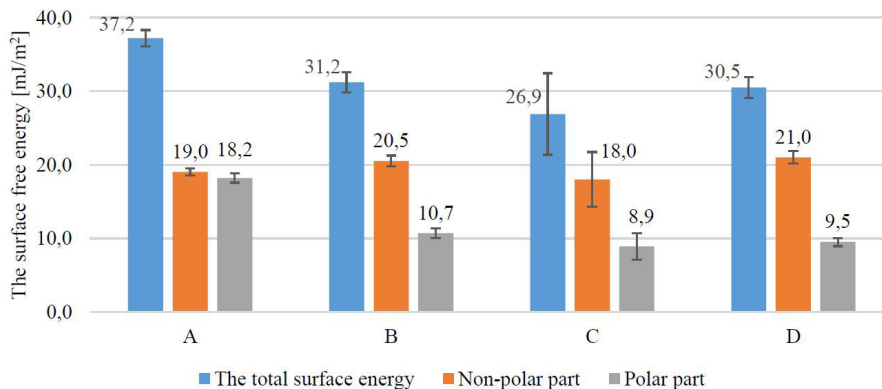

Fig. 2. The results of calculation of surface free energy of EN AW-2017A aluminum alloy (variant of surface preparation method according to Table 1)

Tab. 3. The average value of contact angle and the surface free energy determined by the method of Owens-Wendt together with the components for the EN AW-2017A aluminum alloy samples subjected to the selected surface preparation methods

Variant ¹⁾	The average value of the contact angle [°]		Owens-Wendt method		
	Distilled water	Diodomethane	The surface free energy [mJ/m²]	Non-polar component [mJ/m²]	Polar component [mJ/m²]
A	66,7	66,5	37,2	19,0	18,2
B	77,2	66,4	31,2	20,5	10,7
C	82,6	72,0	26,9	18,0	8,9
D	78,9	66,0	30,5	21,0	9,5

¹⁾ variant of surface preparation method according to Table 1

The highest value of total surface-free energy was found for the samples not subjected to mechanical treatment with abrasive nonwoven. It amounts to 37,2 mJ/m² with a non-polar component equal to 19 mJ/m², whose share in total surface energy is 51.1%. The use of treatment using the non-woven a fiber reduces the total value of the surface free energy. At the same time it can be seen that the change in the share of component values in the total surface free energy compared to the untreated samples. The treated surfaces are characterized by lower values of the polar component of the surface free energy and a smaller share of this component in the total SEP value.

The measurements of surface tension and contact angle during the application of drops of Epidian 5 resin with Z1 hardener on DC01 steel samples were used to determine the components of the surface free energy of the tested adhesive. This adhesive is characterized by a total surface free energy equal to 36,6 mJ/m² of a polar component 27,4 mJ/m² [6].

Based on the determined work of adhesion curves the values of the maximum work of adhesion between the solid and the liquid that forms on the surface the contact angle of a certain value were also determined. Table 4 summarizes the results of calculations.

Wetting envelopes were determined for the analyzed variants of treatment of EN AW-2017A aluminum alloy, which represent the representation of boundary components of surface free energy of the liquid ensuring good wetting (Fig. 3-Fig. 6) [6]. In the graphs, there was marked the point corresponding to the values of components of the surface free energy of the Epidian 5 resin with Z1 hardener.

The diagrams presented in the drawings show that the best wetting conditions for adhesive Epidian 5 with Z1 hardener were obtained for the surface of the EN AW 2017A aluminum alloy that had not been treated (contact angle $\theta=19,48^\circ$). In the case of mechanical treatment with non-woven fabric with different grain size, the value of the surface free energy and the polar component of the mentioned adhesive designate the points on the

Tab. 4. Summary of the values of the work of adhesion between the surface layer of the EN AW-2017A aluminum alloy and the Epidian 5 with the Z1 hardener adhesive while maintaining a specific contact angle, and the maximum value of the work of adhesion possible to be achieved under certain wetting conditions

Variant ¹⁾	Contact angle [°]	Ra [μm]	Max. work of adhesion [mJ/m ²]	Adhesion work Epidian 5/Z1/100:10 [mJ/m ²]
A	19,48	0,11	76,59	71,10
B	46,68	0,59	74,02	61,71
C	56,18	0,40	69,13	56,97
D	50,12	0,41	74,33	60,70

¹⁾ variant of surface preparation method according to Table 1

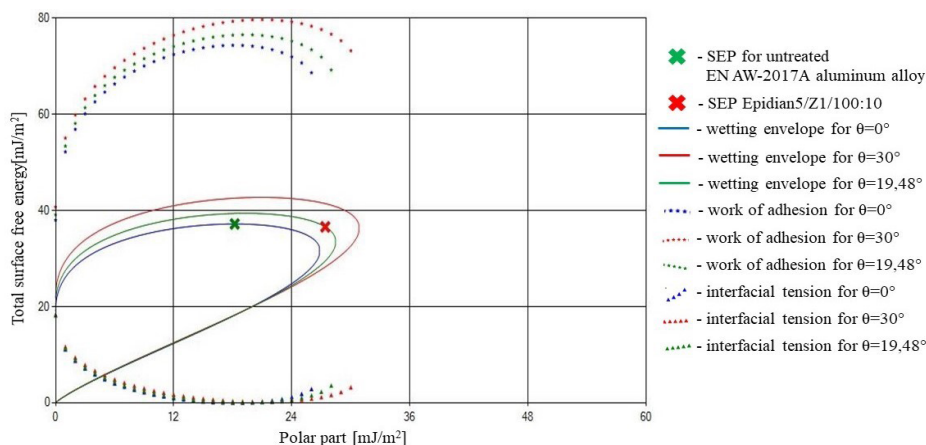

Fig 3. The wetting envelopes, adhesion and interfacial tension curves determined for untreated EN AW-2017A aluminum alloy samples with the marked value of surface free energy of the adhesive Epidian 5 with Z1 hardener

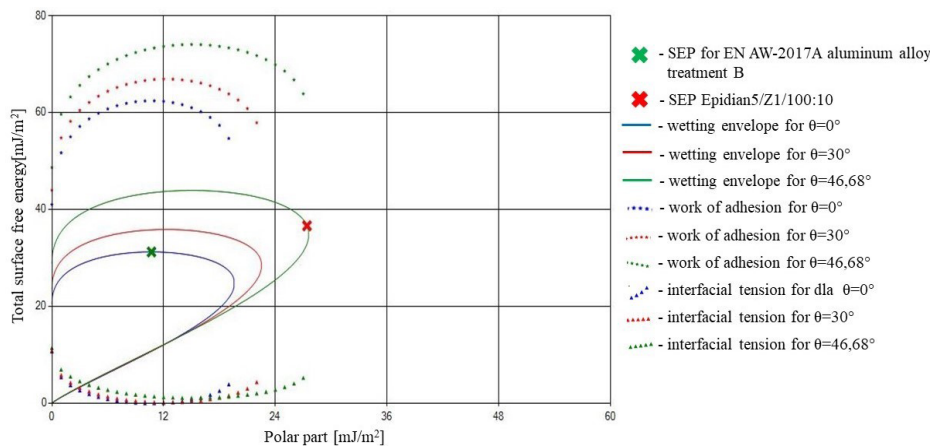

Fig 4. The wetting envelopes, adhesion and interfacial tension curves determined for treated with non-woven fabric with a granulation of 80 EN AW-2017A aluminum alloy samples with the marked value of surface free energy of the adhesive Epidian 5 with Z1 hardener

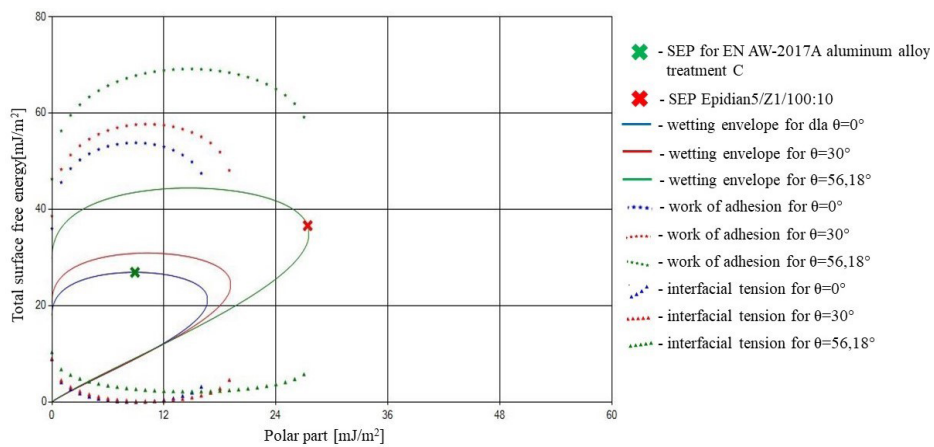

Fig 5. The wetting envelopes, adhesion and interfacial tension curves determined for treated with non-woven fabric with a granulation of 180 EN AW-2017A aluminum alloy samples with marked value of surface free energy of the adhesive Epidian 5 with Z1 hardener

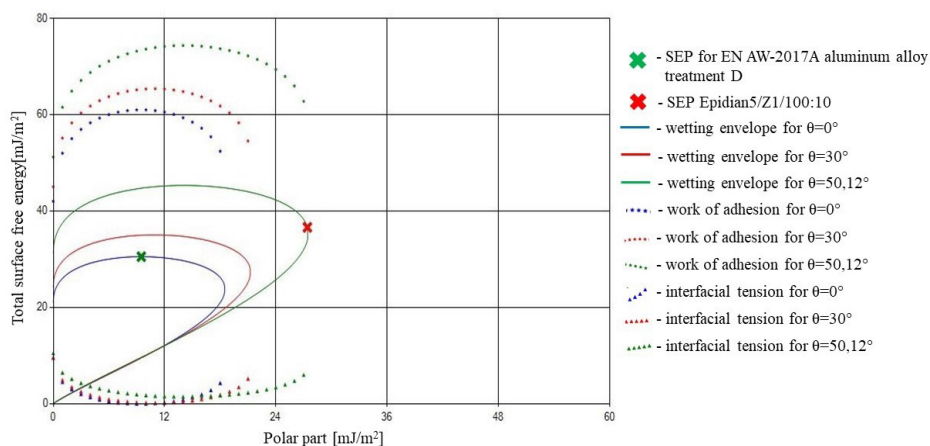

Fig 6. The wetting envelopes, adhesion and interfacial tension curves determined for treated with non-woven fabric with a granulation of 320 EN AW-2017A aluminum alloy samples with marked value of surface free energy of the adhesive Epidian 5 with Z1 hardener

charts that are further away from the wetting envelopes illustrating very good and ideal wetting. Treatment with non-woven fabric adversely affects the surface wettability of adhesive Epidian 5 with Z1 hardener. This is caused by a decrease of the polar component of surface free energy of the treated aluminum, which in turn reduces Van der Waals forces, and thus reduces the value of the work of adhesion due to the increase of the interfacial tension. The values of surface free energy for the aluminum treated non-woven fabric are similar. The change in the strength of connections is therefore here the influence of mechanical and chemical adhesion.

The results of research and analyses lead to the conclusion that the mechanical removal of the oxide layer from the surface of the EN AW-2017 aluminum reduces the surface energy. When comparing variants B, C and D, it can be stated that for the accepted form of machining geometrically developing the surface, there was no effect on the energy properties of the surface layer and the work of adhesion.

Presented at work charts can be helpful for analyzing the possibility of modifying the adhesive in order to achieve, at a given contact angle, the maximum value of the work of adhesion. In the case of the considered methods of preparing the surface of the aluminum alloy EN AW-2017A, the values of the work of adhesion determined for the theoretical contact angles formed between the material and Epidian 5 with the Z1 hardener adhesive do not reach the values corresponding to the maximum. This gives the opportunity to modify the adhesive composition to achieve optimal adhesive properties. At the maximum value of the adhesion work, the minimum value of the interfacial tension is simultaneously achieved. In the case of Epidian 5 with hardener Z1 adhesive, to achieve this state, it was necessary to reduce the polar component of the surface free energy.

Conclusions

The analysis of the wetting ability of the Epidian 5 with hardener Z1 adhesive of the surface of the EN AW-2017A aluminum alloy subjected to the selected methods of treatment in order to obtain different parameters of the geometric development of the surface allowed for the determination of theoretical contact angles between the analyzed adhesive and the material. On the basis of studies it was found that despite the increase in the surface roughness parameters favorable from the point of view of adhesion, treatment with non-woven fabric adversely affects the values of the surface free energy of the EN AW-2017A aluminum alloy as a result of removing the high-energy oxide layer.

The best „matching” of the adhesive and the material was obtained in the case of untreated samples. The points characterizing Epidian 5 with hardener Z1 adhesive are closest to the wetting envelopes corresponding to the ideal wetting angle. In order to ensure the perfect wettability of the EN AW-2017A aluminum alloy surface treated with

non-woven fabric, one should strive to reduce the total surface free energy of the adhesive compositions to values close to the value of the surface free energy of the material, with particular regard to its polar component.

The analysis of the surface free energy of epoxy adhesives for a construction material subjected to the selected methods of surface preparation allowed for a quick analysis of the adhesive's ability to wet the surface of materials. Knowing the components of the free-surface energy of the adhesive, it can be determined without the need for destructive testing, whether it will be able to wet the surface of the material well and what value of work of adhesion will be achieved. The presented analysis allows one to determine the adhesive-surface configuration allowing to achieve optimal adhesive properties.

References

- [1] Boutar Y., Naïmi S., Mezlini S., Ali M.B.S. 2016. “Effect of surface treatment on the shear strength of aluminum adhesive single-lap joints for automotive applications”. *International Journal of Adhesion & Adhesives* (67): 38 43. <http://dx.doi.org/10.1016/j.ijadhadh.2015.12.023>.
- [2] Budhe S., Ghumatkar A., Birajdar N., Banea M.D. 2015. “Effect of surface roughness using different adherend materials on the adhesive bond strength”. *Applied Adhesion Science* 3(20). <https://doi.org/10.1186/s40563-015-0050-4>.
- [3] Domińczuk J. 2011. “Właściwości adhezyjne warstwy wierzchniej materiałów konstrukcyjnych”. *Postęp Nauki i Techniki* (9): 28 37.
- [4] Domińczuk J. 2012. „Wpływ stanu energetycznego warstwy wierzchniej na wytrzymałość połączenia adhezyjnego”. *Postępy Nauki i Techniki* (13): 30 36.
- [5] Domińczuk J., Krawczuk A. 2016. „Analiza zdolności kleju do zwilżania powierzchni o określonych właściwościach energetycznych”. *Technologia i Automatyzyzacja Montażu* (2): 60 64.
- [6] Domińczuk J., Krawczuk A., Kuczmaszewski J. 2016. “Energia powierzchniowa wybranych klejów epoksydowych”. *Technologia i Automatyzyzacja Montażu* (2): 47 52.
- [7] Ghumatkar A., Sekhar R., Sandip Budhe S. 2017. “Experimental study on different adherend surface roughness on the adhesive bond strength”. *Materials Today: Proceedings* 4(8): 7801 7809. <https://doi.org/10.1016/j.matpr.2017.07.115>.
- [8] Hu Y., Yuan B., Cheng F., Hu X. 2019. “NaOH etching and resin pre-coating treatments for stronger adhesive bonding between CFRP and aluminium alloy”. *Composites Part B: Engineering* (178): 107478. <https://doi.org/10.1016/j.compositesb.2019.107478>.
- [9] Kłonica M., Kuczmaszewski J. 2011. „Badania porównawcze wytrzymałości na ścinanie zakładkowych połączeń klejowych po oczyszczeniu mechanicznym i ozonowaniu”. *Technologia i Automatyzyzacja Montażu* (4): 45 48.

- [10] Kłonica M., Kuczmaszewski J. 2015. „Badania porównawcze stanu energetycznego warstwy wierzchniej stopu aluminium AZ91HP po obróbce ścierniej i frezowaniu”. *Mechanik* (8-9): 212-216. <http://dx.doi.org/10.17814/mechanik.2015.8-9.372>.
- [11] Krawczuk A., Domińczuk J. 2015. „Analiza możliwości wykorzystania krzywych zwilżania do optymalizacji procesów adhezyjnych”. *Technologia i Automatyza Montażu* (4): 45-49.
- [12] Leena K., Athira K.K., Bhuvanewari S., Suraj S., Lakshmana Rao V. 2016. “Effect of surface pre-treatment on surface characteristics and adhesive bond strength of aluminium alloy”. *International Journal of Adhesion & Adhesives* (70): 265–270.
- [13] Saleema N., Sarkar D.K., Paynter R.W., Gallant D., Eskandarian M. 2012. “A simple surface treatment and characterization of AA 6061 aluminum alloy surface for adhesive bonding applications”. *Applied Surface Science* (261): 742-748. <http://dx.doi.org/10.1016/j.apsusc.2012.08.091>.
- [14] Wu C., Chen C., He L., Yan W. 2018. “Comparison on damage tolerance of scarf and stepped-lap bonded composite joints under quasi-static loading.” *Composites Part B: Engineering* (155): 19-30. <https://doi.org/10.1016/j.compositesb.2018.08.031>.
- [15] Zain N.M., Ahmad S., Ali E.S. 2014. “Effect of surface treatments on the durability of green polyurethane adhesive bonded aluminium alloy”. *International Journal of Adhesion & Adhesives* (55): 43-55. <http://dx.doi.org/10.1016/j.ijadhadh.2014.07.007>.
- [16] Żimniak Z., Wróblewski R. 2018. „Wpływ aktywacji powierzchni aluminium 7075 na wytrzymałość połączenia klejowego”. *Przegląd Spawalnictwa* 90(2). <http://dx.doi.org/10.26628/ps.v90i2.858>.
- [17] Żenkiewicz M. 2007. „Analiza głównych metod badania swobodnej energii powierzchniowej materiałów polimerowych”. *Polimery* 52(10): 760-767.

dr inż. Jacek Domińczuk
 Politechnika Lubelska, Wydział Mechaniczny, Katedra Informatyzacji i Robotyzacji Produkcji
 ul. Nadbystrzycka 36, 20-618 Lublin, Polska
 e-mail: j.dominczuk@pollub.pl

mgr inż. Anna Krawczuk
 Uniwersytet Przyrodniczy w Lublinie, Wydziału Inżynierii Produkcji, Katedra Eksploatacji Maszyn i Zarządzania Procesami Produkcyjnymi
 ul. Głęboka 28, 20-612 Lublin, Polska
 e-mail: anna.krawczuk@up.lublin.pl

ITM

INDUSTRY EUROPE

3-6.11.2020
 POZNAŃ

www.itm-europe.pl



**PRZEMYSŁ
 ERY CYFROWEJ**

W TYM SAMYM CZASIE

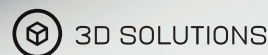
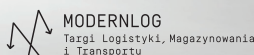

ANALYSIS OF FLAT COMPENSATOR LAPPING IN AN ASSEMBLY PROCESS

Analiza docierania kompensatora płaskiego w procesie montażu

Adam BARYLSKI

ORCID 0000-0003-1672-8445

DOI: 10.15199/160.2020.2.7

Abstract: An approach to analysis of lapping of flat compensator during the assembly of the structural connection was demonstrated. Machining main time and the costs of single-disc lapping process were presented.

Keywords: assembly, compensator, lapping, analysis

Streszczenie: Przedstawiono sposób analizy docierania kompensatora płaskiego podczas montażu połączenia konstrukcyjnego. Wyznaczono czas główny obróbki i koszty operacji docierania jednotarczowego.

Słowa kluczowe: montaż, kompensator, docieranie, analiza

Introduction

Abrasive machining, mainly grinding and lapping, is often applied in the process of the assembly of machine structures, in the case of individual fitment of the components of a given joint or application of the technological compensation [2, 3]. When compensative assembly method is employed, the required length of the closing link is achieved by changing the dimension of one of the component links of the chain of dimensions. It is very important to specify the offset correctly, so as it is not too large because it would extend the time consumption of the assembly process. The advantages of this

compensative assembly method include the possibility of producing the components with larger tolerances. The time consumption of the compensator lapping in the link assembly process makes this method applicable in piece production and low-rate production. Machine lapping is being applied in order to shorten the machining time as much as possible.

In case of unilateral lapping of flat surfaces, a single-disc lapping machines are used, including both machines with weight ballast (Fig. 1a and 1b) – placed in specially designed separators (Fig. 1.e) and machines featuring pneumatic assemblies ballasting lapped parts – through elastic supports (Fig.1c and 1d).

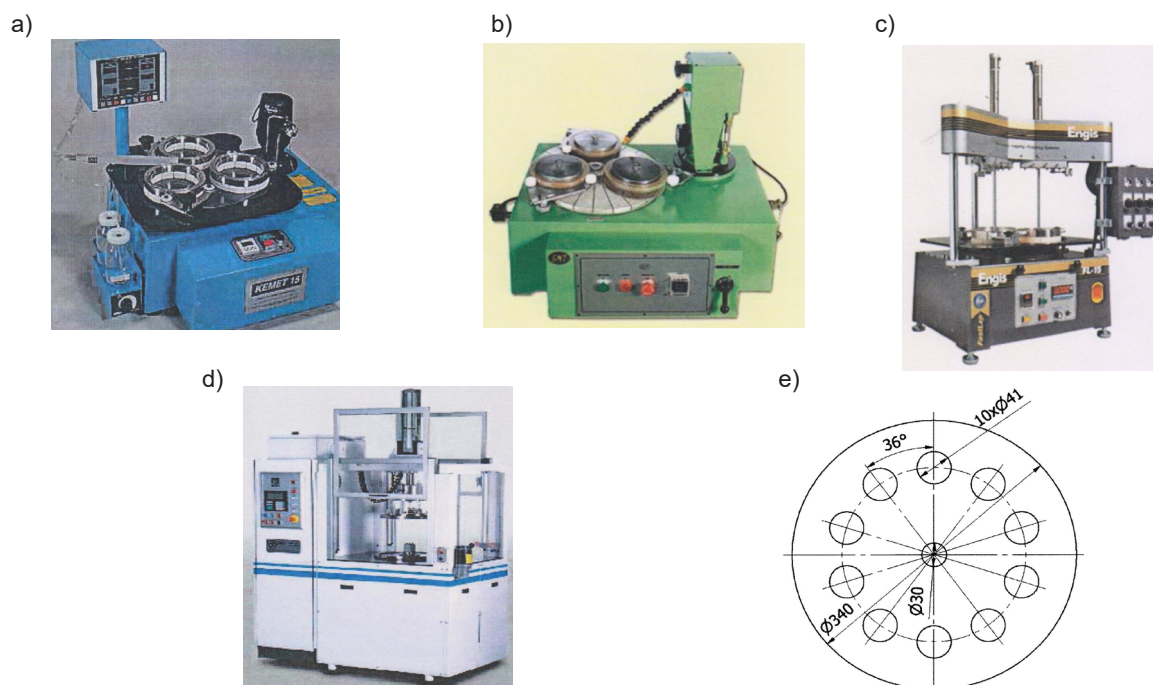

Fig. 1. Single-disc lapping machine: a) model 15 produced by Kemet [6], b) model 06-01 produced by GMT [5], c) model FL-15 produced by Engis [4], d) model LSP-6 produced by Lapmaster [7], e) sample separator

Main time of lapping t_g of a single filling of separators with workpieces (a batch of elements machined at the same time) can be specified with this formula:

$$t_g = q(A \cdot v \cdot p \cdot k_v \cdot k_p \cdot k_z \cdot k_c)^{-1} \quad (1)$$

where:

q – lapping offset (unilateral) [mm],

A – constant depending on the type of a machined material [mm^2/daN],

v – average lapping speed [m/min],

p – unit pressure [kPa],

k_v – coefficient of the influence of lapping speed,

k_p – coefficient of the influence of unit pressure,

k_z – coefficient of the influence of the size of abrasive grains,

k_c – coefficient of the influence of the liquid components of abrasive suspension.

Table 1 contains the experimentally determined values of the constant A and coefficients in the formula (1) during lapping with a suspension based on normal artificial corundum.

For example, in the case of the considered unilateral offset for lapping a ring flat compensator (made of carbide construction steel in a mild condition) with $q = 0,05$ mm, an element whose surface roughness after lapping should not exceed $R_a = 0,16$ μm , a suspension of micro-grains

of artificial corundum 95A number F360/23 was selected. For the adapted unit pressure $p = 100$ kPa, average lapping speed of 60 m/min and application of liquid suspension (volumetric composition: 50% of machine oil and 50% of petroleum) table 1 yields: $A = 448 \cdot 10^{-8}$, $k_v = 0,73$, $k_p = 0,54$, $k_z = 0,62$ and $k_c = 0,84$ (determined average value). Therefore, bearing in mind formula (1), main time of lapping t_g is 10,8 min. As it was exhibited in further experiments, when abrasive suspension based on green silicone carbide (the same grain number) and $p = 80$ kPa were applied, main time obtained was $t_g = 13,5$ min. When lapping is underway, it is necessary to measure the height of compensator, disturbing the process before the calculated time t_g (approx. two minutes earlier). Afterwards, the machining process should be completed in order to obtain the required assembly dimension. When suspension is constantly supplied, it can be assumed that linear performance of lapping is maintained throughout the operation at undeviating level.

In the case of a single-disc lapping, the applied kinematic system (Fig. 4) includes a lapping disc 1 (outer diameter R_3) rotating with angular velocity ω_1 and workpiece separators 2 (fitted in a leading ring with inner radius r_2) rotating concurrently with velocity ω_2 (angular velocity of an imaginable yoke $\omega_j = 0$). Speed of a specific point P located on the surface of a machined workpiece 3 is described (in time function t) by relation [2]:

Table 1. Data for calculating the lapping time

Values of the A constant and coefficients in the formula for calculating the main time of lapping							
Machined material	A [mm^2/daN]						
Steel in mild condition	448 · 10 ⁻⁸						
Hardened steel	374 · 10 ⁻⁸						
	Lapping speed v [m/min]						
	10	20	30	40	50	60	
	Coefficient k_v						
Steel in mild condition	1	0,92	0,86	0,81	0,77	0,73	
Hardened steel	1	0,85	0,76	0,70	0,64	0,60	
	Unit pressure p [kPa]						
	50	60	70	80	90	100	
	Coefficient k_p						
Steel in mild condition	1	0,83	0,74	0,66	0,59	0,54	
Hardened steel	1	0,81	0,73	0,65	0,58	0,52	
	Size of an abrasive grain						
	180	F240/45	F280/37	F360/23	F400/17	F500/13	F600/9
	Coefficient k_z						
Steel in mild condition	1	0,91	0,85	0,62	0,55	0,45	0,38
Hardened steel	1	0,89	0,82	0,60	0,51	0,41	0,33
	Liquid component of abrasive suspension						
Type of liquid	Coefficient k_c						
Machine oil	1						
Petroleum	0,67						

$$v_p(t) = \omega_t [R^2 + r^2 \cdot k^2 + 2R \cdot r \cdot k \cdot \cos(\omega_2 \cdot t)]^{-1/2} \quad (2)$$

where coefficient

$$k = (\omega_t - \omega_2) / \omega_t \quad (3)$$

Figure 5 presents, for example, the variability of lapping speed for a standard single-disc lapping machine at various distance r of the center of a lapped workpiece to the center of the separator (Fig. 4).

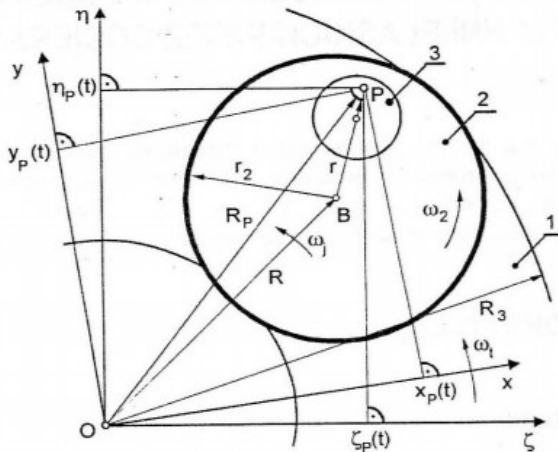

Fig. 4. Kinematic system of single-disc lapping

Knowing the arrangement of lapped compensators in separators and other geometrical and kinematic parameters of the system (including the location of the separator center) formula (2) can be used to determine the value of angular velocity (thus rotation speed) of the lapping disc as a mean value – calculated from the initial and final value of the cycle of variations.

Material costs of lapping are mainly influenced by the output of abrasive suspension which, in the analysed case, is 1.65 ml/min. Taking into consideration the costs of man-hour amounting to 23.70 PLN [11] it is possible to determine a price of lapping a flat technological compensator amounting to 11.06 PLN if normal artificial corundum grain is applied in the process or 13.54 PLN if the suspension of green silicone carbide (with the same grain number) is used.

General remarks

Lapping is not the only machining method applied in the assembly process with technological compensation or in individual fitting of components. Standard grinding or cutting is also applied. In the case of time-consuming manual grinding, the duration of the operation is significantly longer than the duration of machine lapping and, in approximation, it is proportional to the dimensions of the machined surface of a compensator. One of

a)

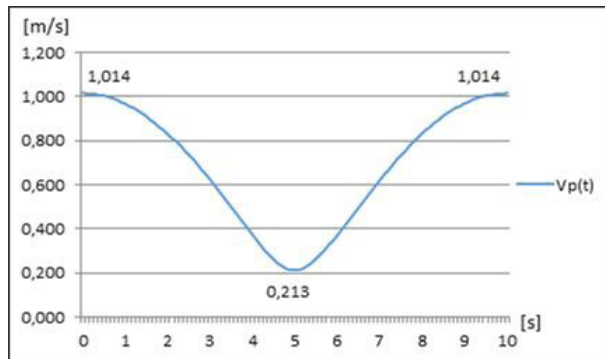

b)

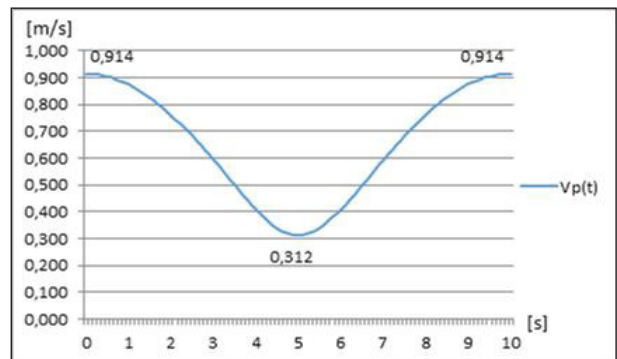

c)

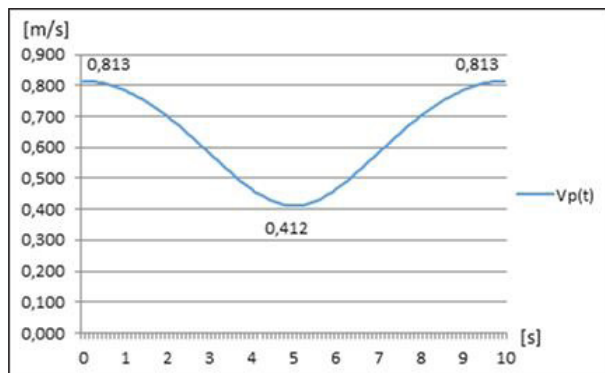

d)

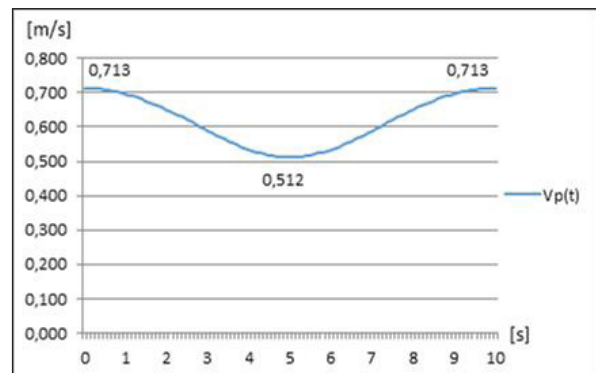

Fig. 5. Values of the instantaneous lapping speed in a system of a standard single-disc lapping machine for: a) $r = 40$ mm, b) $r = 30$ mm, c) $r = 20$ mm, d) $r = 10$ mm ($R = 65$ mm, $\omega_t = 3\pi$ rad/s, $\omega_2 = 0,2\pi$ rad/s)

the advantageous solutions includes the application of grinding with lapping kinematics [1,12,13], which is a method that allows a significant increase of performance – at comparable shape-dimension precision and quality of the machined surface. An important advantage of this innovative machining method on lapping machines, mostly double-disc type, for flat surfaces lies in facilitating the post-process cleaning of workpieces and minimizing the risk of contaminating the surface of workpieces with grinding micro-grains. Successive decreasing of (still high) costs of uniform and segment disc tools for lapping also as far as single-disc lapping machines are concerned, will probably allow finishing machining of flat compensators on a single machine without the need for applying initial grinding. In case of the individual fitting of the components of assembly joint, lapping with a loose abrasant is still a correct machining process, especially when a high precision of a construction node is required.

References

- [1] Barylski A. 2018. „Modułowe konstrukcje narzędzi tarczowych do szlifowania na docierarkach”. *Technologia i Automatykacja Montażu* (3): 45-52.
- [2] Barylski A. 2013. „Obróbka powierzchni płaskich na docierarkach”. Gdańsk: Wydawnictwo Politechniki Gdańskiej.
- [3] Feld M., Barylski A. 1979. „Docieranie. Wytyczne doboru warunków obróbki”. Warszawa: Wydawnictwo WEMA.
- [4] Materiały informacyjne firmy Engis.
- [5] Materiały informacyjne firmy GMT.
- [6] Materiały informacyjne firmy Kemet.
- [7] Materiały informacyjne firmy Lapmaster.
- [8] Materiały informacyjne firmy Melchiorre.
- [9] Materiały informacyjne firmy Peter Wolters.
- [10] Materiały informacyjne firmy Stähli.
- [11] Rutkowska K. 2012. „Wykorzystanie obróbki przez docieranie w operacjach montażowych”. Prowadz. pracę A. Barylski. Gdańsk: WM PG.
- [12] Stähli A.W. 2000. „Flat honing with diamond or CBN grinding discs”. *Industrial Diamond Review* (1): 9-13.
- [13] Uhlmann E., Ardelt Th. 1999. „Influence of Kinematics on the Face Grinding Process on Lapping Machines”. *Annals of the CIRP* (1): 281-284.

prof. dr hab. inż. Adam Barylski
 Politechnika Gdańska
 Wydział Mechaniczny
 ul. G. Narutowicza 11/12, 80-233 Gdańsk, Polska
 e-mail: abarylsk@pg.edu.pl



ZMIANA TERMINU TARGÓW!

Przemysłowa wiosna
 w tym roku na jesieni

STOM

22-24.09.2020

przemyslowawiosna.pl

 STOM-TOOL	 WIRTOPROCESY
 STOM-BLECH & CUTTING	 TEIA
 STOM-ROBOTICS	 CONTROL-STOM
 STOM-LASER	 EXPO SURFACE
 SPAWALNICTWO	 KIELCE FLUID POWER
 DNI DRUKU 3D	

#ZmieniamTerminNieRezygnuję

ASSEMBLY TECHNIQUES AND TECHNOLOGIES

INFORMATION FOR AUTHORS

Please submit to the editorial office author's application form with contact details, a title of the proposed article, number of pages, illustrations and tables and a brief abstract. After receiving information about the acceptance of the proposed paper submit the entire text prepared according to the editorial instructions as well as a complete declaration form.

Submitted articles are subjected to editorial assessment and receive a formal editorial identification number used in further stages of the editorial process. Every submitted article is reviewed. Publication is possible after receiving positive reviews (see review procedure).

The editorial office does not pay royalties.

GUIDELINES FOR PREPARING PAPERS

- Articles for publication in Assembly Techniques and Technologies should have scientific and research character and deal with current issues of the industry.
- Articles must be original, not previously published (if the article is a part of another work i.e. PhD thesis, Habilitation etc. the information about that should be placed in the reference section).
- The article should involve a narrow topic but treated thoroughly without repeating general knowledge information included in the widely known literature.
- If the problem is extensive break it into articles for separate publications.
- Articles should be of a clear and logical structure: the material should be divided into parts with titles reflecting its content. The conclusions should be clearly stated at the end of the paper.
- The article should be adequately supplemented with illustrations, photographs, tables etc. however, their number should be limited to absolute necessity.
- The title of the article should be given in Polish and English as well as the abstract and key words.
- The article should not exceed 8 pages (1 page – 1 800 characters).
- The article should include mailing and e-mail addresses of the author(s).
- The article should be electronically submitted in * doc or * docx format. Equations should be written in the editors, with a clear distinction between 0 and O. If the equations exceed the width of column (8 cm) they must be moved, otherwise use double width column (16 cm).
- The editorial staff does not rewrite the texts or prepare illustrations. Apart from doc, * docx formats it is recommended to submit the source files of illustrations (in *.eps, *.jpg or *.tif format).
- Drawings and graphs must be clear, taking into account the fact that the width of the columns in the magazine is 8 cm, width of the single column - 17 cm, height of the column - 24.5 cm.
- The text on the drawings cut to the size must be legible and not less than 2 mm.
- The authors are required to give at the end of the article a full list of sources used for the paper. The text must include citation references to the position of cited work in the bibliography. The bibliography prepared according to the references in the text must include: books – surname and first letter of the author's name, title, publisher, year and a place of publication (optionally page numbers), magazines – author's name and surname, title of the article, title of the magazine, number, year and optionally page numbers. The bibliography should present the current state of knowledge and take into account publications of world literature.
- The authors guarantee that the contents of the paper and the drawings are originally their property (if not, the source should be indicated). The authors who submit the paper, will receive the following documents from the Publisher SIGMA-NOT to be signed by them:
 - The declaration on granting a licence
 - The licence agreement
 - The Authors' agreement
 on the right of the Publisher to:
 - a) Preservation and reproduction of the article, via production of its copies by paper and electronic way,
 - b) Turnover of the copies on which the article has been preserved – by introduction to market, lending or lease of the copies,
 - c) Making available to the public, including the Internet pages,
 - d) Dissemination as a whole or of its parts for advertisement and/or promotional purposes.
- The editorial staff will document all forms of scientific misconduct, especially violations of the rules of ethics applicable in science.

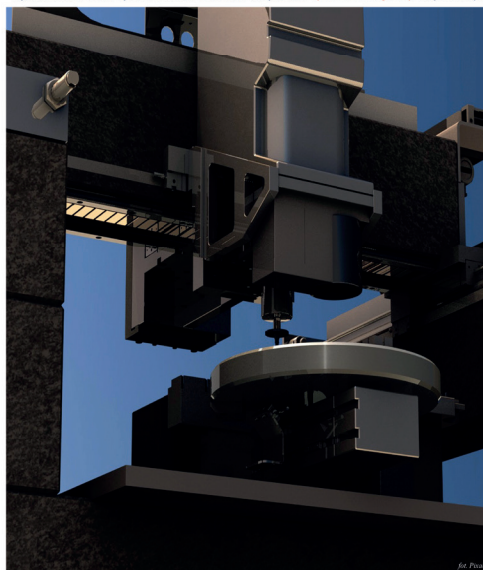

Zapraszamy Autorów do współpracy!

www.tiam.pl

tiam@sigma-not.pl

tel. 22 853 81 13

ITM

INDUSTRY EUROPE

3-6.11.2020

POZNAŃ

ZAPRASZA

mtp
GRUPA

www.itm-europe.pl



Międzynarodowe
Targi Poznańskie

PRZEMYSŁ ERY CYFROWEJ

W TYM SAMYM CZASIE



MODERNLOG
Targi Logistyki, Magazynowania
i Transportu





SUBCONTRACTING
TARGI KOOPERACJI
PRZEMYSŁOWEJ



3D SOLUTIONS
TARGI SKANU I DRUKU

FOCAST



WYDAWNICTWO SIGMA-NOT 

34 TYTUŁY
123 000 PUBLIKACJI

on-line

WYGODNY DOSTĘP
DO ARTYKUŁÓW FACHOWYCH

on-line

WIRTUALNA CZYTELNIĄ

NA PORTALU INFORMACJI TECHNICZNEJ

www.sigma-not.pl

